



User's Guide

NPD4862-00 EN

Copyright and Trademarks

Copyright and Trademarks

No part of this publication may be reproduced, stored in a retrieval system, or transmitted in any form or by any means, electronic, mechanical, photocopying, recording, or otherwise, without the prior written permission of Seiko Epson Corporation. No patent liability is assumed with respect to the use of the information contained herein. Neither is any liability assumed for damages resulting from the use of the information herein. The information contained herein is designed only for use with this Epson product. Epson is not responsible for any use of this information as applied to other products.

Neither Seiko Epson Corporation nor its affiliates shall be liable to the purchaser of this product or third parties for damages, losses, costs, or expenses incurred by the purchaser or third parties as a result of accident, misuse, or abuse of this product or unauthorized modifications, repairs, or alterations to this product, or (excluding the U.S.) failure to strictly comply with Seiko Epson Corporation's operating and maintenance instructions.

Seiko Epson Corporation and its affiliates shall not be liable for any damages or problems arising from the use of any options or any consumable products other than those designated as Original Epson Products or Epson Approved Products by Seiko Epson Corporation.

Seiko Epson Corporation shall not be held liable for any damage resulting from electromagnetic interference that occurs from the use of any interface cables other than those designated as Epson Approved Products by Seiko Epson Corporation.

EPSON® is a registered trademark, and EPSON EXCEED YOUR VISION or EXCEED YOUR VISION is a trademark of Seiko Epson Corporation.

PRINT Image Matching™ and the PRINT Image Matching logo are trademarks of Seiko Epson Corporation. Copyright © 2001 Seiko Epson Corporation. All rights reserved.

Intel® is a registered trademark of Intel Corporation.

PowerPC® is a registered trademark of International Business Machines Corporation.

Epson Scan software is based in part on the work of the Independent JPEG Group.

libtiff

Copyright © 1988-1997 Sam Leffler
Copyright © 1991-1997 Silicon Graphics, Inc.

Permission to use, copy, modify, distribute, and sell this software and its documentation for any purpose is hereby granted without fee, provided that (i) the above copyright notices and this permission notice appear in all copies of the software and related documentation, and (ii) the names of Sam Leffler and Silicon Graphics may not be used in any advertising or publicity relating to the software without the specific, prior written permission of Sam Leffler and Silicon Graphics.

THE SOFTWARE IS PROVIDED "AS-IS" AND WITHOUT WARRANTY OF ANY KIND, EXPRESS, IMPLIED OR OTHERWISE, INCLUDING WITHOUT LIMITATION, ANY WARRANTY OF MERCHANTABILITY OR FITNESS FOR A PARTICULAR PURPOSE.

Copyright and Trademarks

IN NO EVENT SHALL SAM LEFFLER OR SILICON GRAPHICS BE LIABLE FOR ANY SPECIAL, INCIDENTAL, INDIRECT OR CONSEQUENTIAL DAMAGES OF ANY KIND, OR ANY DAMAGES WHATSOEVER RESULTING FROM LOSS OF USE, DATA OR PROFITS, WHETHER OR NOT ADVISED OF THE POSSIBILITY OF DAMAGE, AND ON ANY THEORY OF LIABILITY, ARISING OUT OF OR IN CONNECTION WITH THE USE OR PERFORMANCE OF THIS SOFTWARE.

Microsoft®, Windows®, and Windows Vista® are registered trademarks of Microsoft Corporation.

Apple, Macintosh, Mac OS, and OS X are trademarks of Apple Inc., registered in the U.S. and other countries.

AirPrint is a trademark of Apple Inc.

Google Cloud Print™ is a registered trademark of Google Inc.

Adobe, Adobe Reader, Acrobat, and Photoshop are trademarks of Adobe systems Incorporated, which may be registered in certain jurisdictions.

SDXC Logo is a trademark of SD-3C, LLC.



Memory Stick Duo, Memory Stick PRO Duo, Memory Stick PRO-HG Duo, Memory Stick Micro, and MagicGate Memory Stick Duo are trademarks of Sony Corporation.



General Notice: Other product names used herein are for identification purposes only and may be trademarks of their respective owners. Epson disclaims any and all rights in those marks.

Copyright © 2013 Seiko Epson Corporation. All rights reserved.

Contents

Copyright and Trademarks

Copyright and Trademarks.	2
-----------------------------------	---

Introduction

Where to Find Information.	7
Caution, Important and Note.	7
Operating System Versions.	7
Using Epson Connect Service.	8

Important Instructions

Safety Instructions.	9
Product Advisories and Warnings.	9
Setting up/using the product.	9
Using the product with a wireless connection	11
Using memory cards.	11
Using the LCD screen/touchpad.	11
Handling ink cartridges.	12
Restrictions on Copying.	12

Getting to Know Your Product

Available Features.	13
Product Parts.	14
Guide to the Control Panel.	17
XP-410 Series.	17
XP-310 Series.	17
XP-210 Series.	19

Paper and Media Handling

Introduction to Using, Loading, and Storing Media.	20
Storing paper.	20
Selecting Paper.	20
Paper type settings on the LCD screen.	22
Paper type settings from the printer driver.	22
Loading Paper and Envelopes.	23
Inserting a Memory Card.	26
Placing Originals.	28

Copying

Copying Documents.	29
Basic copying for XP-310 Series/XP-410 Series	29
Basic copying for XP-210 Series.	29
Copy Mode Menu List.	30

Printing

Basic Operation from the Control Panel (XP-310 Series/XP-410 Series only).	31
Printing photos from a memory card.	31
Print photos mode menu list.	32
Printing using the More Functions / Personal Stationery menus.	32
More Functions / Personal Stationery mode menu list.	35
Basic Operation from Your Computer.	36
Printer driver and status monitor.	36
Basic Printing.	38
Canceling Printing.	41
Other Options.	43
Printing photos the easy way.	43
Product presets (for Windows only).	44
2-sided printing (for Windows only).	44
Fit to page printing.	46
Pages per sheet printing.	47
Sharing the Product for Printing.	48
Setup for Windows.	48
Setup for Mac OS X.	50

Scanning

Let's Try Scanning.	51
Starting a Scan.	51
Image Adjustment Features.	53
Basic Scanning from the Control Panel.	55
For XP-310 Series/XP-410 Series.	56
For XP-210 Series.	56
Scan mode menu list.	56
Basic Scanning from Your Computer.	57
Scanning in Full Auto Mode.	57
Scanning in Home Mode.	58
Scanning in Office Mode.	60
Scanning in Professional Mode.	62
Previewing and Adjusting the Scan Area.	64
Various Types of Scanning.	66

Contents

Scanning a Magazine.	66	Using the control panel (XP-310 Series/ XP-410 Series).	98
Scanning Multiple Documents to a PDF File	68	Using the control panel (XP-210 Series).	98
Scanning a Photo.	70	Cleaning the Print Head.	99
Software Information.	71	Using the Head Cleaning utility for Windows	100
Starting Epson Scan Driver.	71	Using the Head Cleaning utility for Mac OS X	100
Starting Other Scanning Software.	72	Using the control panel (XP-310 Series/ XP-410 Series).	100
		Using the control panel (XP-210 Series).	101
Menu List of Control Panel		Aligning the Print Head.	101
Copy Mode.	73	Using the Print Head Alignment utility for Windows.	101
Print Photo Mode.	74	Using the Print Head Alignment utility for Mac OS X.	101
Scan Mode.	75	Using the control panel (XP-310 Series/ XP-410 Series).	102
More Functions Mode.	76	Saving Power.	102
Personal Stationery Mode.	77	For Windows.	103
Wi-Fi Setup Mode.	78	For Mac OS X.	103
Setup Mode.	78	Using the control panel (XP-310 Series/ XP-410 Series).	103
		Making Network Service Settings.	104
Replacing Ink Cartridges		Cleaning the Product.	105
Ink Cartridge Safety Instructions, Precautions, and Specifications.	80	Cleaning the exterior of the product.	105
Safety instructions.	80	Cleaning the interior of the product.	106
Precautions on ink cartridge replacement.	81	Transporting the Product.	106
Ink Cartridge Specifications.	82	Checking and Installing Your Software.	109
Checking the Ink Cartridge Status.	83	Checking the software installed on your computer.	109
For Windows.	83	Installing the software.	109
For Mac OS X.	84	Uninstalling Your Software.	110
Using the control panel.	84	For Windows.	110
Temporarily Printing with Black Ink When Color Ink Cartridges are Expended.	85	For Mac OS X.	111
For Windows.	85		
For Mac OS X.	87	Transferring Data Using an External Storage Device	
Conserving Black Ink When the Cartridge Is Low (For Windows Only).	88	Precautions on Storage Devices.	112
Replacing an Ink Cartridge.	89	Copying Files Between a Storage Device and Your Computer.	112
Using the control panel (XP-310 Series/ XP-410 Series).	89	Copying files to your computer.	112
Using the control panel (XP-210 Series).	92	Saving files to a storage device.	113
For Windows.	95		
For Mac OS X.	96		
		Error Indicators	
Maintaining Your Product and Software		Error Messages on the Control Panel (XP-310 Series/XP-410 Series).	114
Checking the Print Head Nozzles.	97		
Using the Nozzle Check utility for Windows	97		
Using the Nozzle Check utility for Mac OS X	97		

Contents

Error Indications on the Control Panel (XP-210 Series)	115
--	-----

Troubleshooting for Printing/Copying

Diagnosing the Problem.	118
Checking product status.	119
Paper Jams.	122
Removing jammed paper from inside the product.	122
Preventing paper jams.	125
Reprinting after a paper jam (for Windows only).	125
Print Quality Help.	126
Horizontal banding.	127
Vertical banding or misalignment.	127
Incorrect or missing colors.	128
Blurry or smeared print.	128
Miscellaneous Printout Problems.	129
Incorrect or garbled characters.	129
Incorrect margins.	129
Printout has a slight slant.	129
Size or position of copied image is incorrect.	129
Inverted image.	130
Blank pages print.	130
Printed side is smeared or scuffed.	130
Printing is too slow.	130
Paper Does Not Feed Correctly.	131
Paper does not feed.	131
Multiple pages feed.	131
Paper is improperly loaded.	132
Paper is not ejected fully or is wrinkled.	132
The Product Does Not Print.	132
All lights are off.	132
Only the power light is on.	132
An ink error is indicated after you replace the cartridge.	133
Increasing the Print Speed (For Windows Only)	134
Other Problem.	135
Printing plain papers quietly.	135

Troubleshooting for Scanning

Problems Indicated by Messages on the LCD Screen or Status Light.	136
Problems When Starting a Scan.	136
Using the button.	137
Using scanning software other than Epson Scan driver.	138

Problems When Feeding Paper.	138
The paper gets dirty.	138
Multiple sheets of paper are fed.	138
Problems With Scanning Time.	138
Problems With Scanned Images.	139
Scan quality is unsatisfactory.	139
The scanning area or direction is unsatisfactory.	140
Problems Remain After Trying All Solutions.	141

Product Information

Ink Cartridges.	142
System Requirements.	142
For Windows.	142
For Mac OS X.	143
Technical Specifications.	143
Printer specifications.	143
Scanner specifications.	145
Network interface specification.	146
Memory card.	146
Mechanical.	147
Electrical.	148
Environmental.	149
Standards and approvals.	149
Interface.	150

Where To Get Help

Technical Support Web Site.	151
Contacting Epson Support.	151
Before Contacting Epson.	151
Help for Users in Europe.	152
Help for Users in Taiwan.	152
Help for Users in Australia.	153
Help for Users in Singapore.	153
Help for Users in Hong Kong.	154

Index

Introduction

Where to Find Information

The latest version of the following manuals are available on the Epson support website.

<http://www.epson.eu/Support> (Europe)

<http://support.epson.net/> (other than Europe)

Start Here (paper):

Provides you with information on setting up the product and installing the software.

User's Guide (PDF):

Provides you with detailed operating, safety, and troubleshooting instructions. See this guide when using this product with a computer.

To view the PDF manual, you need Adobe Acrobat Reader 5.0 or later, or Adobe Reader.

Network Guide (PDF):

Provides network administrators with information on both the printer driver and network settings.

Caution, Important and Note

Caution, Important, and Note in this manual are indicated as below and have the following meaning.



Caution

must be followed carefully to avoid bodily injury.



Important

must be observed to avoid damage to your equipment.

Note

contain useful tips and restrictions on product operation.

Operating System Versions

In this manual, the following abbreviations are used.

Windows 8 refers to Windows 8 and Windows 8 Pro.

Windows 7 refers to Windows 7 Home Basic, Windows 7 Home Premium, Windows 7 Professional, and Windows 7 Ultimate.

Introduction

- ❑ Windows Vista refers to Windows Vista Home Basic Edition, Windows Vista Home Premium Edition, Windows Vista Business Edition, Windows Vista Enterprise Edition, and Windows Vista Ultimate Edition.
- ❑ Windows XP refers to Windows XP Home Edition, Windows XP Professional x64 Edition, and Windows XP Professional.
- ❑ Mac OS X refers to Mac OS X 10.5.8, 10.6.x, 10.7.x, 10.8.x.

Using Epson Connect Service

Using Epson Connect and other companies' services, you can easily print directly from your smartphone, tablet PC or laptop, anytime and practically anywhere even across the globe! The services available vary by product. (➔ [“Available Features”](#) on page 13)

For more information about the printing and other services, visit the following URL:

<https://www.epsonconnect.com/> (Epson Connect portal site)

<http://www.epsonconnect.eu> (Europe only)



Note:

You can make network service settings using a Web browser on your computer, smartphone, tablet PC, or laptop that is connected to the same network as the product.

➔ [“Making Network Service Settings”](#) on page 104

Important Instructions

Important Instructions

Safety Instructions

Read and follow these instructions to ensure safe use of this product. Make sure you keep this guide for future reference. Also, be sure to follow all warnings and instructions marked on the product.

- Use only the power cord supplied with the product and do not use the cord with any other equipment. Use of other cords with this product or the use of the supplied power cord with other equipment may result in fire or electric shock.
- Be sure your AC power cord meets the relevant local safety standard.
- Never disassemble, modify, or attempt to repair the power cord, plug, printer unit, scanner unit, or options by yourself, except as specifically explained in the product's guides.
- Unplug the product and refer servicing to qualified service personnel under the following conditions:
The power cord or plug is damaged; liquid has entered the product; the product has been dropped or the casing damaged; the product does not operate normally or exhibits a distinct change in performance. Do not adjust controls that are not covered by the operating instructions.
- Place the product near a wall outlet where the plug can be easily unplugged.
- Do not place or store the product outdoors, near excessive dirt or dust, water, heat sources, or in locations subject to shocks, vibrations, high temperature or humidity.
- Take care not to spill liquid on the product and not to handle the product with wet hands.
- Keep this product at least 22 cm away from cardiac pacemakers. Radio waves from this product may adversely affect the operation of cardiac pacemakers.
- If the LCD screen is damaged, contact your dealer. If the liquid crystal solution gets on your hands, wash them thoroughly with soap and water. If the liquid crystal solution gets into your eyes, flush them immediately with water. If discomfort or vision problems remain after a thorough flushing, see a doctor immediately. Some products are not equipped with the LCD screen.

Note:

The following provides safety instructions for ink cartridges.

➔ ["Replacing Ink Cartridges" on page 80](#)

Product Advisories and Warnings

Read and follow these instructions to avoid damaging the product or your property. Make sure you keep this guide for future reference.

Setting up/using the product

- Do not block or cover the vents and openings in the product.

Important Instructions

- ❑ Use only the type of power source indicated on the product's label.
- ❑ Avoid using outlets on the same circuit as photocopiers or air control systems that regularly switch on and off.
- ❑ Avoid electrical outlets controlled by wall switches or automatic timers.
- ❑ Keep the entire computer system away from potential sources of electromagnetic interference, such as loudspeakers or the base units of cordless telephones.
- ❑ The power-supply cords should be placed to avoid abrasions, cuts, fraying, crimping, and kinking. Do not place objects on top of the power-supply cords and do not allow the power-supply cords to be stepped on or run over. Be particularly careful to keep all the power-supply cords straight at the ends and the points where they enter and leave the transformer.
- ❑ If you use an extension cord with the product, make sure that the total ampere rating of the devices plugged into the extension cord does not exceed the cord's ampere rating. Also, make sure that the total ampere rating of all devices plugged into the wall outlet does not exceed the wall outlet's ampere rating.
- ❑ If you plan to use the product in Germany, the building installation must be protected by a 10 or 16 amp circuit breaker to provide adequate short-circuit protection and over-current protection for the product.
- ❑ When connecting the product to a computer or other device with a cable, ensure the correct orientation of the connectors. Each connector has only one correct orientation. Inserting a connector in the wrong orientation may damage both devices connected by the cable.
- ❑ Place the product on a flat, stable surface that extends beyond the base of the product in all directions. If you place the product by the wall, leave more than 10 cm between the back of the product and the wall. The product will not operate properly if it is tilted at an angle.
- ❑ When storing or transporting the product, avoid tilting it, placing it vertically, or turning it upside down; otherwise ink may leak.
- ❑ Allow spaces behind the product for the cables, and space above the product so that you can fully raise the document cover.
- ❑ Leave enough space in front of the product for the paper to be fully ejected.
- ❑ Avoid places subject to rapid changes in temperature and humidity. Also, keep the product away from direct sunlight, strong light, or heat sources.
- ❑ Do not insert objects through the slots in the product.
- ❑ Do not put your hand inside the product or touch the ink cartridges during printing.
- ❑ Do not touch the white flat cable inside the product.
- ❑ Do not use aerosol products that contain flammable gases inside or around the product. Doing so may cause fire.
- ❑ Do not move the ink cartridge holder by hand; otherwise, you may damage the product.
- ❑ Always turn the product off using the ⏻ button. Do not unplug the product or turn off the power at the outlet until the LCD screen has turned off completely or the ⏻ light stops flashing.

Important Instructions

- ❑ Before transporting the product, make sure that the print head is in the home (far right) position and the ink cartridges are in place.
- ❑ Be careful not to trap your fingers when closing the scanner unit.
- ❑ If you are not going to use the product for a long period, be sure to unplug the power cord from the electrical outlet.
- ❑ Do not press too hard on the scanner glass when placing the originals.
- ❑ During the life of your product it may be necessary to replace the waste ink pad when it has become full. Whether and how often this is required will vary according to the number of pages you print, the type of material that you print and the number of cleaning cycles that the product performs. Epson Status Monitor, your LCD, or lights on the control panel will advise you when this part needs replacing. The need for replacement of the pad does not mean that your product has ceased to operate in accordance with its specifications. The replacement of this part is a routine product servicing activity within the product's specification and is not a problem which requires repair. The Epson warranty does not therefore cover the cost of this replacement. If your product needs the pad replacing this can be performed for you by any authorised Epson service provider. It is not a user-serviceable part.

Using the product with a wireless connection

- ❑ Do not use this product inside medical facilities or near medical equipment. Radio waves from this product may adversely affect the operation of electrical medical equipment.
- ❑ Do not use this product near automatically controlled devices such as automatic doors or fire alarms. Radio waves from this product may adversely affect these devices, and could lead to accidents due to malfunction.

Using memory cards

Note:

The availability of this feature varies by product.

- ❑ Do not remove a memory card or turn off the product while the memory card light is flashing.
- ❑ The methods for using memory cards vary according to card type. Be sure to refer to the documentation packaged with your memory card for details.
- ❑ Use only memory cards compatible with the product.

➔ [“Memory card” on page 146](#)

Using the LCD screen/touchpad

Note:

The availability of this feature varies by product.

- ❑ The LCD screen may contain a few small bright or dark spots, and because of its features it may have an uneven brightness. These are normal and do not indicate that it is damaged in any way.

Important Instructions

- ❑ Only use a dry, soft cloth to clean the LCD screen. Do not use liquid or chemical cleansers.
- ❑ The exterior cover of the LCD screen could break if it receives a heavy impact. Contact your dealer if the panel surface chips or cracks, and do not touch or attempt to remove the broken pieces.
- ❑ For XP-410 Series
The touchpad is a capacitive touch panel, which responds only when touched directly with a finger. The panel may not respond when touched with wet hands, gloved hands, or touched through a protective sheet or sticker.
- ❑ Press the touch panel and touchpad gently with your finger. Do not press force or operate with your nails.
- ❑ Do not operate by a sharp edge thing such as a ball point pen, sharp pencil, stylus pen and so on.
- ❑ Condensation inside the panel due to abrupt changes in temperature or humidity may cause performance to deteriorate.

Handling ink cartridges

We will provide ink-related safety instructions and product advice/warnings in the linked section (before “Replacing Ink Cartridges” section).

➔ [“Replacing Ink Cartridges” on page 80](#)

Restrictions on Copying

Observe the following restrictions in order to ensure the responsible and legal use of the product.

Copying of the following items is prohibited by law:

- ❑ Bank bills, coins, government-issued marketable securities, government bond securities, and municipal securities
- ❑ Unused postage stamps, pre-stamped postcards, and other official postal items bearing valid postage
- ❑ Government-issued revenue stamps, and securities issued according to legal procedure

Exercise caution when copying the following items:

- ❑ Private marketable securities (stock certificates, negotiable notes, checks, etc.), monthly passes, concession tickets, etc.
- ❑ Passports, driver's licenses, warrants of fitness, road passes, food stamps, tickets, etc.

Note:

Copying these items may also be prohibited by law.

Responsible use of copyrighted materials:

- ❑ Products can be misused by improperly copying copyrighted materials. Unless acting on the advice of a knowledgeable attorney, be responsible and respectful by obtaining the permission of the copyright holder before copying published material.

Getting to Know Your Product

Available Features

Check what is available for your product.

Features		XP-410 Series	XP-310 Series	XP-210 Series
Print	from a PC	✓	✓	✓
	from a memory card	✓	✓	-
Copy	Standard copy	✓	✓	✓
	Borderless copy	✓	✓	-
Scan	from a PC	✓	✓	✓
	from product to a PC	✓	✓	✓
	from product to a memory card	✓	-	-
Epson Connect services	iPrint	✓	✓	✓
	Email Print	✓	✓	✓*
	Remote Print Driver	✓	✓	✓*
	Scan to Cloud	✓	-	-
Other companies' services	AirPrint	✓	✓	✓*
	Google Cloud Print	✓	✓	✓*

* XP-212/XP-213/XP-216 do not support these functions.

Note:

The illustrations in this manual are from a similar product model. Although they may differ from your actual product, the method of operation is the same.

Getting to Know Your Product

Product Parts

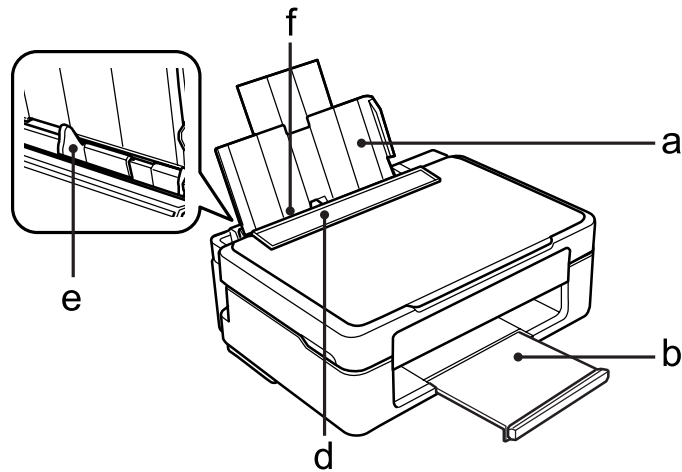
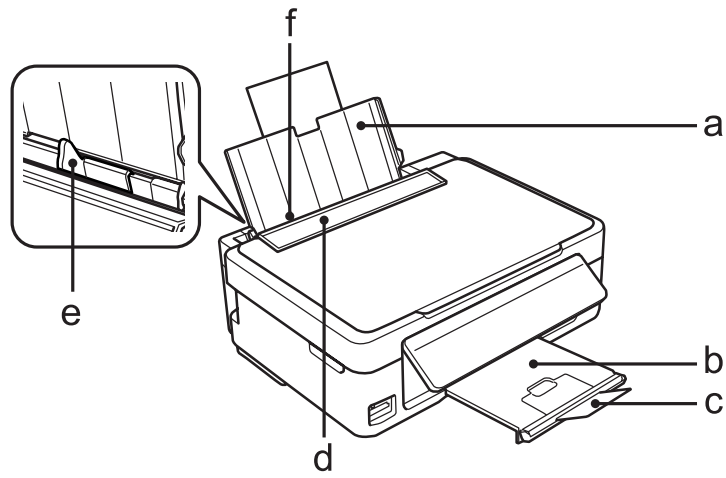

a.	Paper support
b.	Output tray
c.	Stopper
d.	Feeder guard
e.	Edge guide
f.	Sheet feeder

Getting to Know Your Product

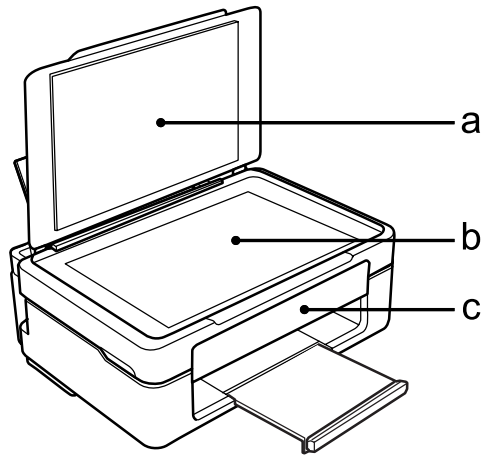
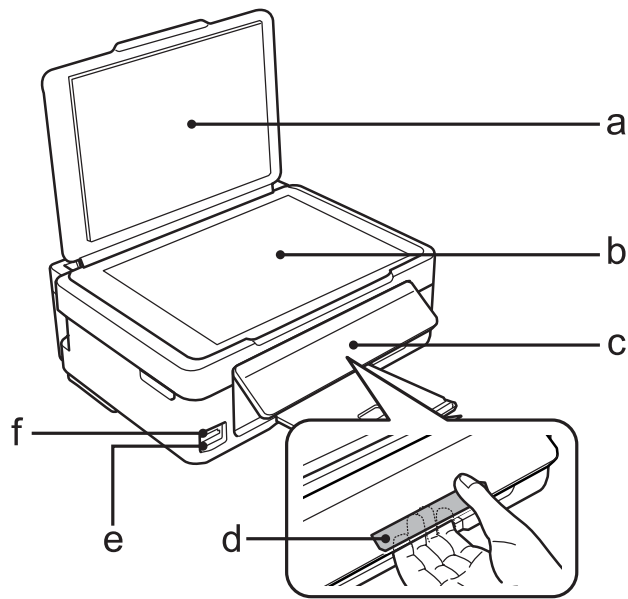

a.	Document cover
b.	Scanner glass
c.	Control panel
d.	Release lever (rear of the control panel)
e.	Memory card slot
f.	Memory card light

Getting to Know Your Product

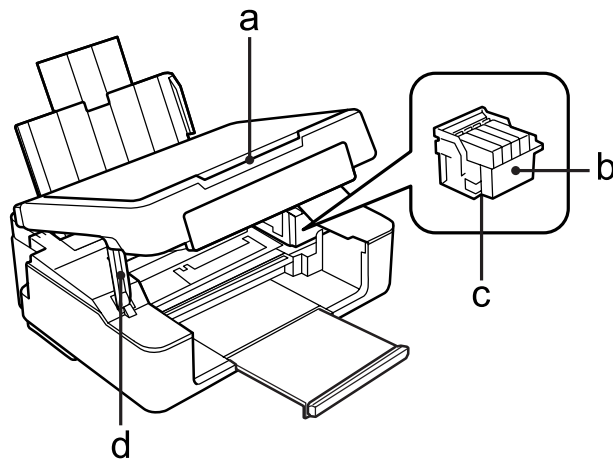
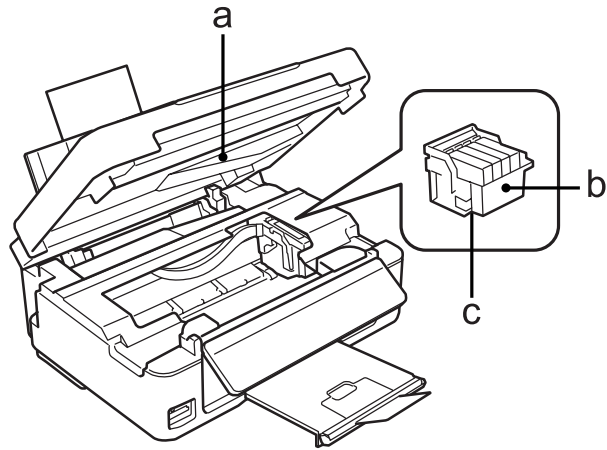

a.	Scanner Unit
b.	Ink cartridge holder
c.	Print head (under the ink cartridge holder)
d.	Scanner unit support

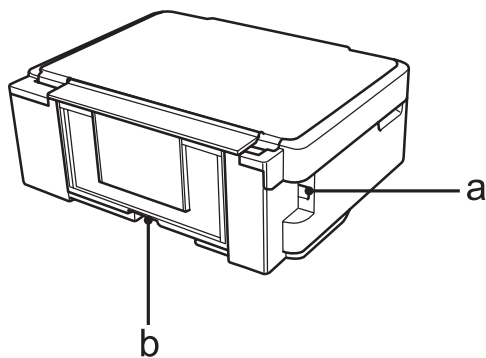

a.	USB connector for connecting to a computer
b.	AC inlet

Guide to the Control Panel

Note:

Although the control panel design and menu and option names and other items in the LCD display may slightly differ from the actual product, the method of operation is the same.

XP-410 Series

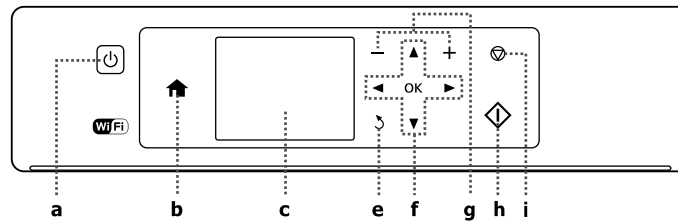

XP-310 Series

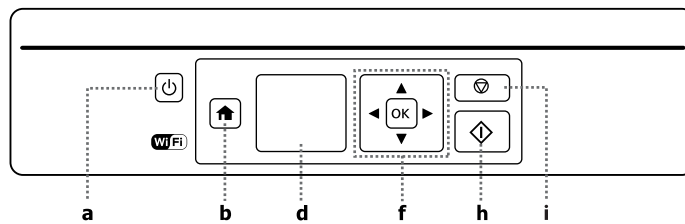









	Buttons/Lights/Icons	Function
a		Turns the product on and off. The button light stays on when the product is on. Flashes when the product is receiving data, printing/copying/scanning, replacing an ink cartridge, charging ink, or cleaning the print head.
b		Returns to the top menu.
c	-	LCD screen (2.5-inch)
d	-	LCD screen (1.44-inch)
e		Cancels/returns to the previous menu.
f		Press , , , to select menus. Press OK to confirm the setting you have selected and go to next screen.
g	+ , -	Sets the number of copies and prints.
h		Starts the operation you selected.
i		Stops the ongoing operation or initialize the current settings. For 1.44-inch display model, this also allows you to return to the previous screen.
-		An icon displayed at the upper left on the LCD screen. Shows the network status. ➔ "Network status icon:" on page 18

Getting to Know Your Product







	Buttons/Lights/Icons	Function
-		<p>An icon displayed only on the 2.5-inch LCD screen. Indicates the status as follows.</p> <p>Green: Epson Connect services are online.</p> <p>Orange: Epson Connect services are suspended.</p> <p>Gray: Epson Connect services are unavailable.</p> <p>➔ "Using Epson Connect Service" on page 8</p>

Network status icon:

XP-410 Series

Icons	Status
	Wi-Fi network error/searching
	Connected to a Wi-Fi network (signal strength: Fair)
	Connected to a Wi-Fi network (signal strength: Good)
	Connected to a Wi-Fi network (signal strength: Excellent)
	Indicates Ad Hoc Connection is on
	Displays the printer is connected via Simple AP mode
	Displays the printer is connected via Wi-Fi Direct mode
	Processing a Wi-Fi connection

XP-310 Series





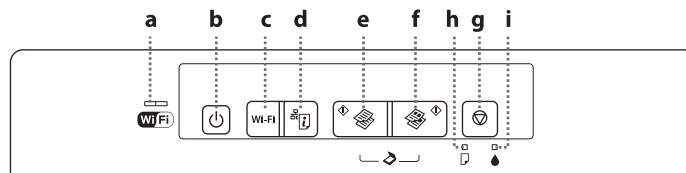

Icons	Status
	Wi-Fi network error/searching
	Connected to a Wi-Fi network (signal strength: Fair)
	Connected to a Wi-Fi network (signal strength: Good)
	Connected to a Wi-Fi network (signal strength: Excellent)
	Indicates Ad Hoc Connection is on
	Displays the printer is connected via Simple AP mode
	Displays the printer is connected via Wi-Fi Direct mode

Getting to Know Your Product



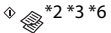
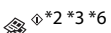

Icons	Status
	Processing a Wi-Fi connection

XP-210 Series



	Buttons/Lights	Function
a		The green light (left) stays on while the product is connected to a Wi-Fi network. If only the orange light (right) is flashing, a network error has occurred. ➔ "Error Indications on the Control Panel (XP-210 Series)" on page 115
b	 *1 *4	Turns the product on or off. The button light stays on when the product is on. Flashes when the product is receiving data, printing/copying/scanning, replacing an ink cartridge, charging ink, or cleaning the print head.
c	Wi-Fi*5	Press to clear a network error. Press for 3 seconds to start making AOSS/WPS push button settings.
d	 *1*5	Prints a network status sheet.
e	 *2 *3 *6	Starts monochrome copy. Press for 3 seconds to copy in draft mode.
f	 *2 *3 *6	Starts color copy. Press for 3 seconds to copy in draft mode.
g	 *2*4	<p>Cancels a print job, copy job, or scan job and stops printing or scanning.</p> <p>Hold this button down for 3 seconds (until the power light flashes) to run print head cleaning.</p> <p>When the ink light turns on, press this button to start the ink cartridge replacement process.</p> <p>When you need to replace an ink cartridge before it is expended (when the ink light is off), hold this button down for 6 seconds (until the print head moves) to start the replacement process.</p> <p>➔ "Replacing an Ink Cartridge" on page 89</p>
h		➔ "Error Indications on the Control Panel (XP-210 Series)" on page 115
i		➔ "Error Indications on the Control Panel (XP-210 Series)" on page 115

*1 While pressing  turn on the product to return the network settings to their defaults.

*2 Press   or   and  at the same time to make 20 copies.

*3 You can scan your original and save it in PDF format on your computer by pressing the two start buttons simultaneously.

*4 While pressing , turn on the product to print the nozzle check. ➔ ["Checking the Print Head Nozzles" on page 97](#)

*5 Press the Wi-Fi and  buttons simultaneously to start WPS PIN code auto connect setting.

*6 For users in Belgium, draft mode is not available.

Paper and Media Handling

Introduction to Using, Loading, and Storing Media

You can achieve good results with most types of plain paper. However, coated papers provide superior prints because they absorb less ink.

Epson provides special papers that are formulated for the ink used in Epson ink jet products, and recommends these papers to ensure high-quality results.

When loading special paper distributed by Epson, read the instruction sheets packed with the paper first and keep the following points in mind.

Note:

- ❑ Load the paper into the rear paper feed printable side up. The printable side is usually whiter or glossier. See the instruction sheets packed with the paper for more information. Some types of paper have cut corners to help identify the correct loading direction.
- ❑ If the paper is curled, flatten it or curl it slightly in the opposite direction before loading. Printing on curled paper may cause ink to smear on your prints. Do not use the paper that is folded, wavy or torn.

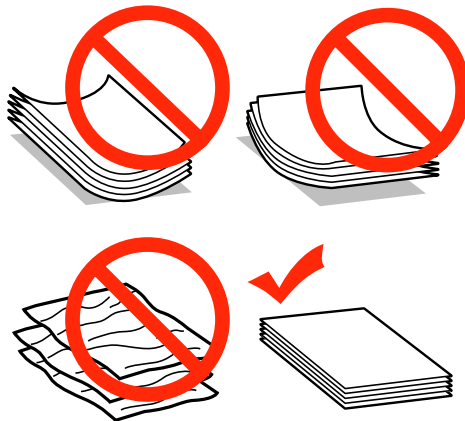

Storing paper

Return unused paper to the original package as soon as you finish printing. When handling special media, Epson recommends storing your prints in a resealable plastic bag. Keep unused paper and prints away from high temperature, humidity, and direct sunlight.

Selecting Paper

The table below lists supported papers. Loading capacity and borderless print availability varies by paper as shown.

Paper and Media Handling

Media Type	Size	Loading capacity (sheets)		Borderless printing
		XP-310 Series/ XP-410Series	XP-210Series	
Plain paper* ¹	Letter* ²	up to 11mm	up to 6mm	-
	A4* ²	up to 11mm	up to 6mm	-
	B5* ²	up to 11mm	up to 6mm	-
	A5* ²	up to 11mm	up to 6mm	-
	A6* ²	up to 11mm	up to 6mm	-
	Legal	1	1	-
	User Defined	1	1	-
Envelope	#10	10	5	-
	DL	10	5	-
	C6	10	5	-
Epson Bright White Ink Jet Paper	A4* ²	80	40	-
Epson Photo Quality Ink Jet Paper	A4	80	40	-
Epson Matte Paper - Heavyweight	A4	20	20	✓
Epson Photo Paper	A4	20	10	✓
	10 × 15 cm (4 × 6 in.)	20	10	✓
	13 × 18 cm (5 × 7 in.)	20	10	✓
Epson Premium Glossy Photo Paper	A4	20	10	✓
	10 × 15 cm (4 × 6 in.)	20	10	✓
	13 × 18 cm (5 × 7 in.)	20	10	✓
	16:9 wide size (102 × 181mm)	20	10	✓
Epson Premium Semigloss Photo Paper	A4	20	10	✓
	10 × 15 cm (4 × 6 in.)	20	10	✓
Epson Ultra Glossy Photo Paper	A4	20	10	✓
	10 × 15 cm (4 × 6 in.)	20	10	✓
	13 × 18 cm (5 × 7 in.)	20	10	✓

Paper and Media Handling

Media Type	Size	Loading capacity (sheets)		Borderless printing
		XP-310 Series/ XP-410 Series	XP-210 Series	
Epson Glossy Photo Paper	A4	20	10	✓
	10 × 15 cm (4 × 6 in.)	20	10	✓
	13 × 18 cm (5 × 7 in.)	20	10	✓

*1 Paper with a weight of 64 g/m² (17 lb) to 90 g/m² (24 lb).

*2 The loading capacity for manual 2-sided printing is 30 sheets for XP-310 Series/XP-410 Series and 15 sheets for XP-210 Series.

Note:

The availability of special media varies by location. For the latest information on media available in your area, contact Epson support.

➔ [“Technical Support Web Site”](#) on page 151

Paper type settings on the LCD screen

The product automatically adjusts itself for the type of paper you select in your print settings. That is why the paper type setting is so important. It tells your product what kind of paper you are using and adjusts the ink coverage accordingly. The table below lists the settings you should choose for your paper.

For this paper	LCD paper type
Plain paper	Plain Paper
Epson Bright White Ink Jet Paper	
Epson Ultra Glossy Photo Paper	Photo Paper
Epson Premium Glossy Photo Paper	
Epson Premium Semigloss Photo Paper	
Epson Glossy Photo Paper	
Epson Photo Paper	
Epson Matte Paper - Heavyweight	Matte
Epson Photo Quality Ink Jet Paper	

Paper type settings from the printer driver

The product automatically adjusts itself for the type of paper you select in your print settings. That is why the paper type setting is so important. It tells your product what kind of paper you are using and adjusts the ink coverage accordingly. The table below lists the settings you should choose for your paper.

Paper and Media Handling

For this paper	Printer driver paper type
Plain paper*	plain papers
Epson Bright White Ink Jet Paper*	
Epson Ultra Glossy Photo Paper*	Epson Ultra Glossy
Epson Premium Glossy Photo Paper*	Epson Premium Glossy
Epson Premium Semigloss Photo Paper*	Epson Premium Semigloss
Epson Glossy Photo Paper*	Epson Glossy
Epson Photo Paper*	Epson Photo
Epson Matte Paper – Heavyweight*	Epson Matte
Epson Photo Quality Ink Jet Paper*	
Envelopes	Envelope

* These paper types are compatible with Exif Print and PRINT Image Matching. For more information, refer to the documentation that came with the Exif Print or PRINT Image Matching compatible digital camera.

Loading Paper and Envelopes

Follow these steps to load paper.

Note:

The illustrations in this section may vary depending on the product.

- 1 Flip the feeder guard forward.

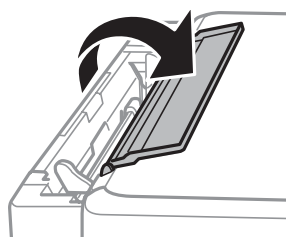

Paper and Media Handling

- 2** Slide out the paper support and the output tray and then raise the stopper.

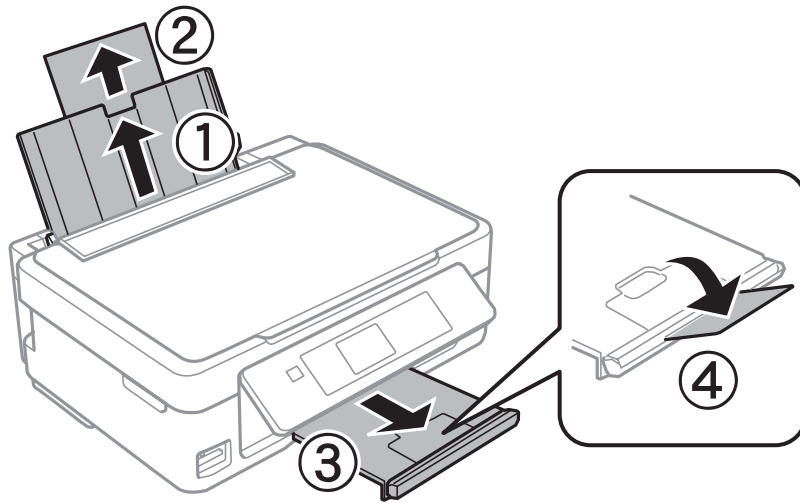

Note:
The XP-210 Series does not have a stopper ④.

- 3** Slide the edge guide to the left.

- 4** Fan and align the edges of the paper sheets. Then load them with the printable side up, against the right side of the sheet feeder.

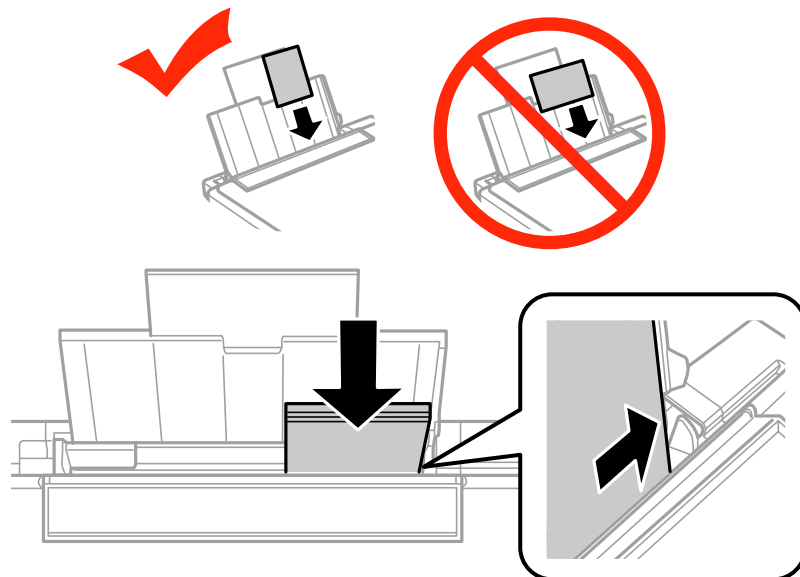

Paper and Media Handling

Note:

- The printable side is often whiter or brighter than the other side.
- Always load paper into the sheet feeder short edge first, even when you are printing landscape-oriented pictures.
- You can use paper with binding holes. Load only one sheet of paper at a time. Make sure you adjust the size of your file to avoid printing over the binding holes.

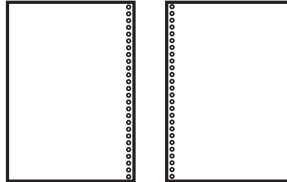

- When loading envelopes, load the short edge first with the flap facing down.

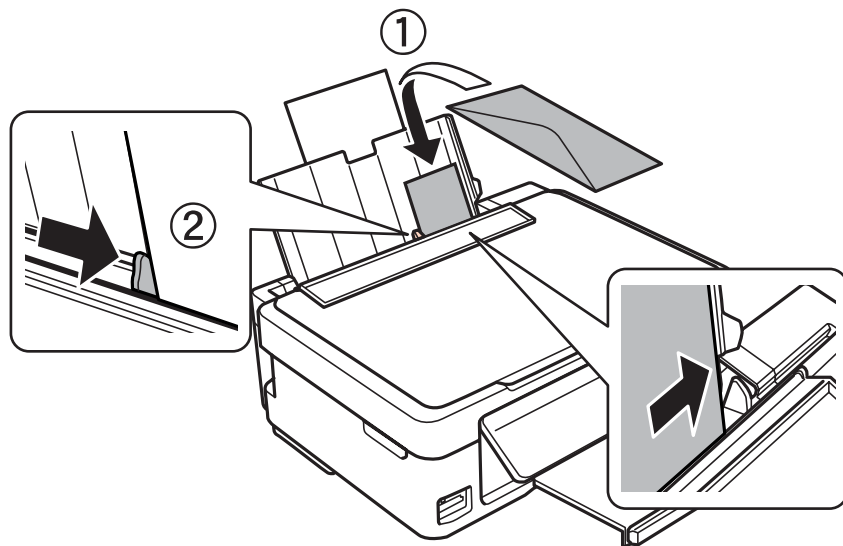

- Do not use envelopes that are curled, folded, or glued or that have plastic windows.
- Flatten the envelope and the flaps before loading.

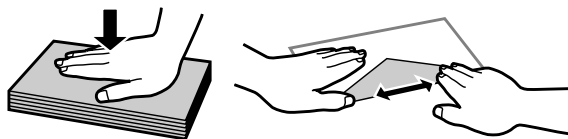

- Flatten the leading edge of the envelope before loading.
- Avoid using envelopes that are too thin, as they may curl during printing.

Paper and Media Handling

- 5** Slide the edge guide against the left edge of the paper, but not too tightly.

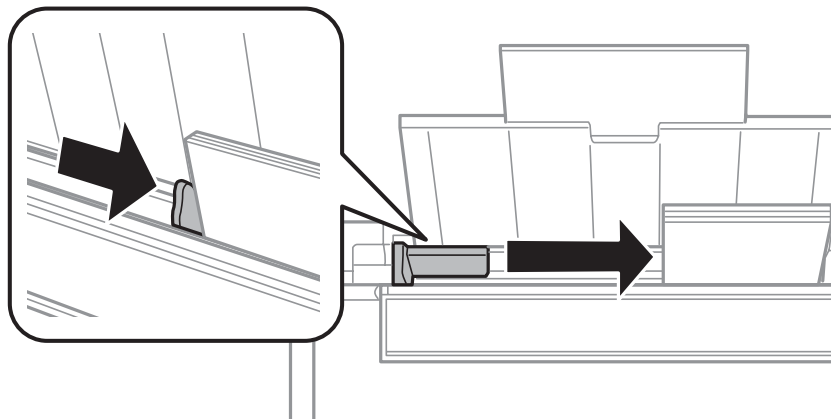

Note:

For plain paper, do not load paper above the ▼ arrow mark inside the edge guide.

For Epson special media, make sure the number of sheets is less than the limit specified for the media.

➔ [“Selecting Paper” on page 20](#)

- 6** Flip the feeder guard back.

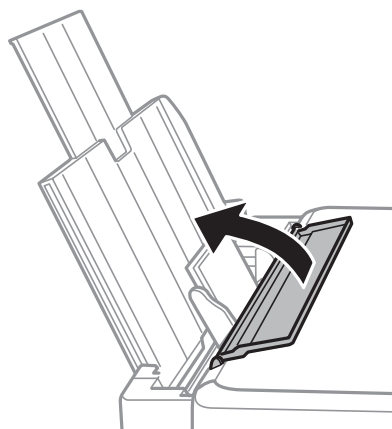

To prevent foreign materials from getting into the product, make sure you flip the feeder guard back when you have finished printing.

Inserting a Memory Card

This function is available with XP-310 Series/XP-410 Series.

You can print photos in a memory card or save a scanned data in a memory card. The following memory cards are supported.

SD, SDHC, SDXC, Memory Stick Duo, Memory Stick PRO Duo, Memory Stick PRO-HG Duo, MagicGate Memory Stick Duo

The following memory cards are available with an adapter.

Paper and Media Handling



Important

Make sure you attach an adapter before inserting the card into the slot, otherwise the card may get stuck.

- miniSD, microSD, miniSDHC, microSDHC, microSDXC

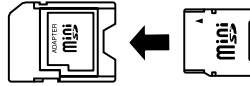

- Memory Stick Micro

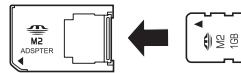

1

Insert one card at a time.

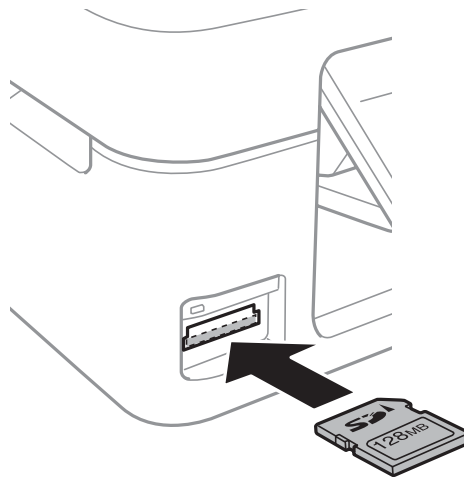

2

Check the light stays on.

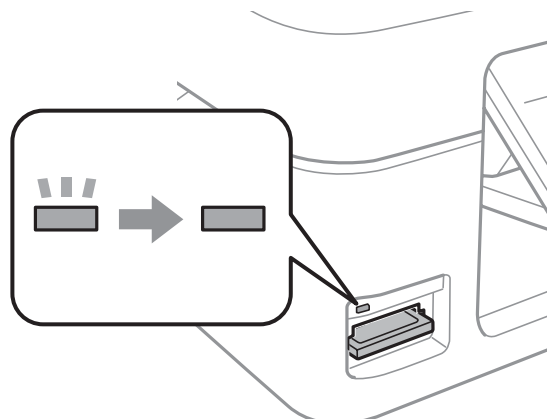

□ = on, □ = flashing

Paper and Media Handling

! *Important*

- ❑ Do not try to force the card all the way into the slot. It should not be fully inserted.
- ❑ Do not remove the memory card while the light is flashing. The data in the memory card may be lost.

Placing Originals

- 1** Open the document cover and place your original face-down on the scanner glass.

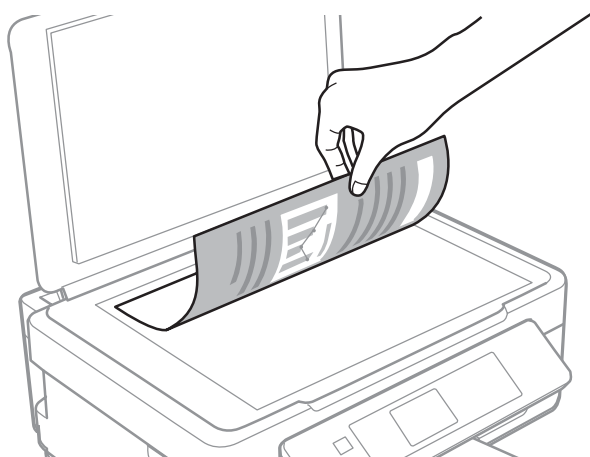

- 2** Slide the original to the corner.

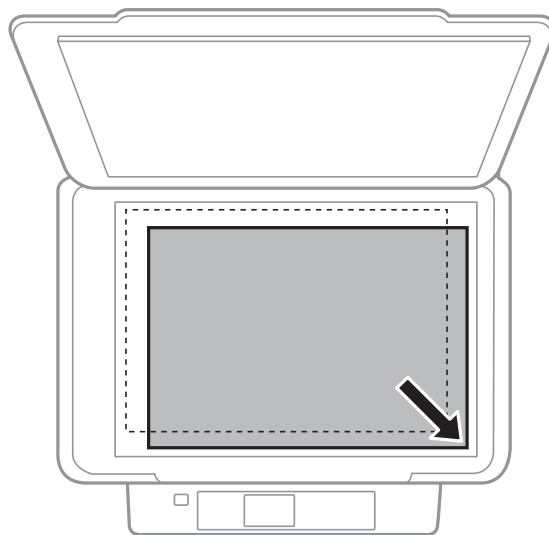

Note:

See the following sections if any problems occur with the scanning area or the scanning direction when using EPSON Scan.

- ➔ [“The edges of your original are not scanned” on page 140](#)
- ➔ [“Multiple documents are scanned into a single file” on page 140](#)

- 3** Close the cover gently.

Copying

Copying Documents

Basic copying for XP-310 Series/XP-410 Series

Follow the steps below to copy documents.

Note for XP-410 Series:

To copy photos, select **More Functions** from the Home menu, and select **Copy/Restore Photos**, then follow the on-screen instructions. You can copy one photo or multiple photos of different sizes at the same time, as long as they are larger than 30 x 40 mm.

- 1 Load paper.
➔ [“Loading Paper and Envelopes” on page 23](#)
- 2 Place your original(s) on the scanner glass.
➔ [“Placing Originals” on page 28](#)
- 3 Enter the **Copy** mode from the **Home** menu.
- 4 Set the number of copies using the + or - button (use ▲ or ▼ for XP-310 Series).
- 5 Select **Color** or **B&W**.
- 6 Press **OK** to display the copy setting menus. For XP-310 Series, press **OK** and then press ▼.
- 7 Select the appropriate copy settings such as layout, paper size, paper type, and copy quality. Use ▲ or ▼ to select a setting item and use ◀ or ▶ to change the setting. For XP-310 Series, press **OK** to save the changes.
- 8 Press ◊ to start copying.

Basic copying for XP-210 Series

Follow the steps below to copy documents.









- 1 Load paper.
➔ [“Loading Paper and Envelopes” on page 23](#)
- 2 Place your original(s) on the scanner glass.
➔ [“Placing Originals” on page 28](#)

Copying

3

Press   or   to start copying.

Note:

- Press   or   for 3 seconds to copy in draft mode. For users in Belgium, draft mode is not available.
- Press   or   and  at the same time to make 20 copies.

Copy Mode Menu List

Refer to the section below for the Copy mode menu list.

➔ [“Copy Mode” on page 73](#)

Printing

Basic Operation from the Control Panel (XP-310 Series/ XP-410 Series only)

Printing photos from a memory card

Follow the steps below to print photos directly from a memory card.

Note for XP-410 Series:

You can print photos in various layouts. Select **More Functions** from the Home menu, and select **Photo Layout Sheet**, then follow the on-screen instructions.

- 1 Load photo paper.
➔ [“Loading Paper and Envelopes” on page 23](#)
- 2 Insert a memory card.
➔ [“Inserting a Memory Card” on page 26](#)
- 3 Enter **Print Photos** mode from the Home menu.
- 4 Use ◀ or ▶ to select a photo and set the number of copies using the + or - button (use ▲ or ▼ for XP-310 Series). Repeat this step for all the photos you want to print.

Note for XP-410 Series:

- If you have more than 999 images on your memory card, images are automatically divided into groups and the group selection screen is displayed. Select the group that contains the image you want to print. Images are sorted by the date they were taken.
- To select another group, select **Print Photos** on the **Home** menu. Then press ▼ and select **Select Group**.

- 5 Display the print setting menus. For XP-410 Series, press ▼ and select **Print Settings**. For XP-310 Series, press **OK** and then press ▼.

Note for XP-410 Series:

You can crop and enlarge your photo. Select **Crop/Zoom**, and then make the settings.

- 6 Select the appropriate print settings such as paper size and paper type. Use ▲ or ▼ to select a setting item and use ◀ or ▶ to change the setting. For XP-310 Series, press **OK** to save the changes.
- 7 Press ◇ to start printing.





Print photos mode menu list

Refer to the section below for the Print Photos mode menu list.

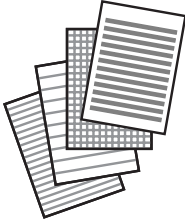

➔ [“Print Photo Mode” on page 74](#)

Printing using the More Functions / Personal Stationery menus

More Functions and **Personal Stationery** provide you with many special menus that make printing easy and fun! Select **More Functions** or **Personal Stationery** from the Home menu, and then see the explanations below to select the menu you want.

Menu		Function
<p>Copy/Restore Photos (XP-410 Series only)</p>		<p>You can make faithful copies of your originals. If your original photo is faded, you can restore color to bring it back to life. You can copy one photo or multiple photos of different sizes at the same time, as long as they are larger than 30 × 40 mm.</p>
<p>Photo Layout Sheet (XP-410 Series only)</p>		<p>You can print photos stored on a memory card in various layouts. Follow the on-screen instructions to print.</p>
<p>Lined Papers</p>		<p>You can print lined paper, graph paper, and music paper. Follow the on-screen instructions to print.</p>
<p>Writing Papers</p>		<p>You can print your own lined paper with or without a photo set as the background. Follow the on-screen instructions to print.</p>

Printing

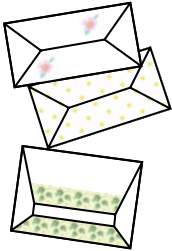
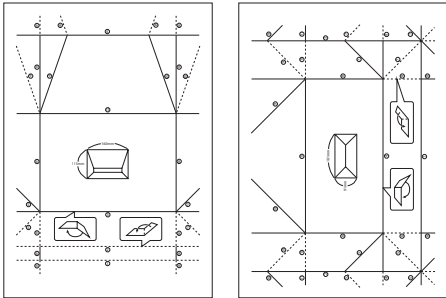
Menu		Function
Calendar		<p>You can print monthly or weekly calendars. For monthly calendars, you can specify the year and month. Follow the on-screen instructions to print.</p>
Message card (XP-410 Series only)		<p>You can create your own message cards with or without a photo or a pre-designed image set as the decoration.</p> <p>➔ “Printing message cards (XP-410 Series only)” on page 33</p>
Origami Envelope (XP-410 Series only)		<p>You can create original envelopes with or without pre-designed images set as the background or as decoration. Two types of envelope are available. After printing, fold the paper following the instruction sheet that can be printed from the Origami Envelope Instruction menu.</p> <p>➔ “Printing origami envelopes (XP-410 Series only)” on page 34</p>
Origami Envelope Instruction (XP-410 Series only)		<p>You can print an instruction sheet that shows you how to fold the paper you printed using the Origami Envelope function into an envelope.</p> <p>➔ “Printing origami envelopes (XP-410 Series only)” on page 34</p>

Printing message cards (XP-410 Series only)

You can create original message cards with or without a photo or pre-designed symbol or pattern as the decoration.

Follow the steps below to make message cards.

- 1 Insert a memory card if you want to use a photo as the decoration for the message card.
➔ [“Inserting a Memory Card” on page 26](#)
- 2 Select **More Functions**.
- 3 Select **Personal Stationery**.

Printing

- 4 Select **Message Card**.
- 5 Select the paper type.
- 6 Select an image source.
You can use a pre-designed icon, symbol, or your own photo as the decoration for the message card.
- 7 Select an icon or a photo.
- 8 Select the image position.
- 9 Select the line type.
- 10 Select the line color.
- 11 Select the print layout.
- 12 Load A4 size paper to print a message card.
→ [“Loading Paper and Envelopes” on page 23](#)
- 13 Set the number of copies.
- 14 Press \diamond to start printing.

Printing origami envelopes (XP-410 Series only)

You can create original envelopes with or without pre-designed symbols or patterns as the background or as decoration. Two types of envelope are available. After printing, fold the paper following the instruction sheet that can be printed from the **Origami Envelope Instruction** menu.

- 1 Select **More Functions**.
- 2 Select **Personal Stationery**.
- 3 Select **Origami**.
- 4 Select **Origami Envelope**.
- 5 Select an icon.

Printing

- 6 Select whether or not to print fold lines on the envelope.
- 7 Select the image position.
- 8 Select an envelope size.
- 9 Load A4 size paper to print envelopes.
➔ [“Loading Paper and Envelopes” on page 23](#)
- 10 Set the number of copies.
- 11 Press \diamond to start printing the origami envelope.
- 12 If you select **Yes** when a message is displayed asking whether or not you want to continue printing, go back to step 10. If you select **No**, go to the next step.
- 13 Select **Origami Envelope Instruction**.
- 14 Select an envelope size.
- 15 Load A4 size paper to print an origami envelope instruction sheet.
➔ [“Loading Paper and Envelopes” on page 23](#)
- 16 Set the number of copies.
- 17 Press \diamond to start printing the origami envelope instruction sheet.
- 18 Use the origami envelope instruction sheet to make the folds for the origami envelope in the correct order.

Note:

Place the instruction sheet on top of your envelope and fold both sheets together. When finished, unfold them and remove the instruction sheet. After that, fold the envelope only, using the creases in the paper as a guide.

More Functions / Personal Stationery mode menu list

Refer to the section below for the More Functions/Personal Stationery mode menu list.

- ➔ [“More Functions Mode” on page 76](#)
- ➔ [“Personal Stationery Mode” on page 77](#)

Basic Operation from Your Computer

Printer driver and status monitor

The printer driver lets you choose from a wide variety of settings to get the best printing results. The status monitor and the printer utilities help you check the product and keep it in top operating condition.

Note for Windows users:

- ❑ Your printer driver automatically finds and installs the latest version of the printer driver from Epson's Web site. Click the **Software Update** button in your printer driver's **Maintenance** window, and then follow the on-screen instructions. If the button does not appear in the **Maintenance** window, point at **All Programs** or **Programs** in the Windows Start menu, and check in the **EPSON** folder.*

* For Windows 8:

If the button does not appear in the **Maintenance** window, right-click on the **Start** screen, or swipe from the bottom or top edge of the **Start** screen and select **All apps**, then select **Software Update** from **EPSON** category.

- ❑ If you want to change the language of the driver, select the language you want to use from the **Language** setting in your printer driver's **Maintenance** window. Depending on the location, this function may not be available.

Accessing the printer driver for Windows

You can access the printer driver from most Windows applications, the desktop or the taskbar.

To make settings that apply only to the application you are using, access the printer driver from that application.

To make settings that apply to all of your Windows applications, access the printer driver from the desktop or the taskbar.

Refer to the following sections to access the printer driver.

Note:

Screen shots of the printer driver windows in this User's Guide are from Windows 7.

From Windows applications

- 1 Click **Print** or **Print Setup** on the File menu.
- 2 In the window that appears, click **Printer**, **Setup**, **Options**, **Preferences**, or **Properties**. (Depending on your application, you may need to click one or a combination of these buttons.)

From the desktop

- ❑ **Windows 8:**
Select **Desktop**, **Settings** charm, and **Control Panel**. Then select **Devices and Printers** from the **Hardware and Sound** category. Right-click on the product, or press and hold the product and select **Printing preferences**.
- ❑ **Windows 7:**
Click the start button, select **Devices and Printers**. Then right-click the product and select **Printing preferences**.

Printing

- ❑ **Windows Vista:**
Click the start button, select **Control Panel**, and then select **Printer** from the **Hardware and Sound** category. Then select the product and then click **Select printing preferences**.
- ❑ **Windows XP:**
Click **Start**, **Control Panel**, (**Printers and Other Hardware**), then **Printers and Faxes**. Select the product, then click **Printing Preferences** on the File menu.

From the shortcut icon on the taskbar

Right-click the product icon on the taskbar, then select **Printer Settings**.

To add a shortcut icon to the Windows taskbar, first access the printer driver from the desktop as described above. Next, click the **Maintenance** tab, the **Extended Settings** button, and then the **Monitoring Preferences** button. In the Monitoring Preferences window, select the **Register the shortcut icon to the task bar** check box.

Getting information through online help

In the printer driver window, try one of the following procedures.

- ❑ Right-click the item, then click **Help**.
- ❑ Click the  button at the top right of the window, then click the item (for Windows XP only).

Accessing the printer driver for Mac OS X

The table below describes how to access the printer driver dialog.

Dialog Box	How to Access It
Page Setup	Click Page Setup on the File menu of your application. <i>Note:</i> <i>Depending on your application, the Page Setup menu may not appear in the File menu.</i>
Print	Click Print on the File menu of your application.
Epson Printer Utility 4	For Mac OS X 10.8 or 10.7, click System Preferences on the Apple menu and then click Print & Scan . Select your product from the Printers list box, click Options & Supplies, Utility , and then click Open Printer Utility . For Mac OS X 10.6, click System Preferences on the Apple menu and then click Print & Fax . Select your product from the Printers list box, click Options & Supplies, Utility , and then click Open Printer Utility . For Mac OS X 10.5, click System Preferences on the Apple menu and then click Print & Fax . Select your product from the Printers list box, click Open Print Queue and then click Utility button.

Printing

Basic Printing

Note:

- The screen shots in this manual may vary depending on the model.
- Before you print, load paper properly.
➔ [“Loading Paper and Envelopes” on page 23](#)
- Refer to the section below for the printable area.
➔ [“Printable area” on page 144](#)
- After completing the settings, print one test copy and examine the results before printing an entire job.

Basic product settings for Windows

- 1 Open the file you want to print.
- 2 Access the printer settings.
➔ [“Accessing the printer driver for Windows” on page 36](#)

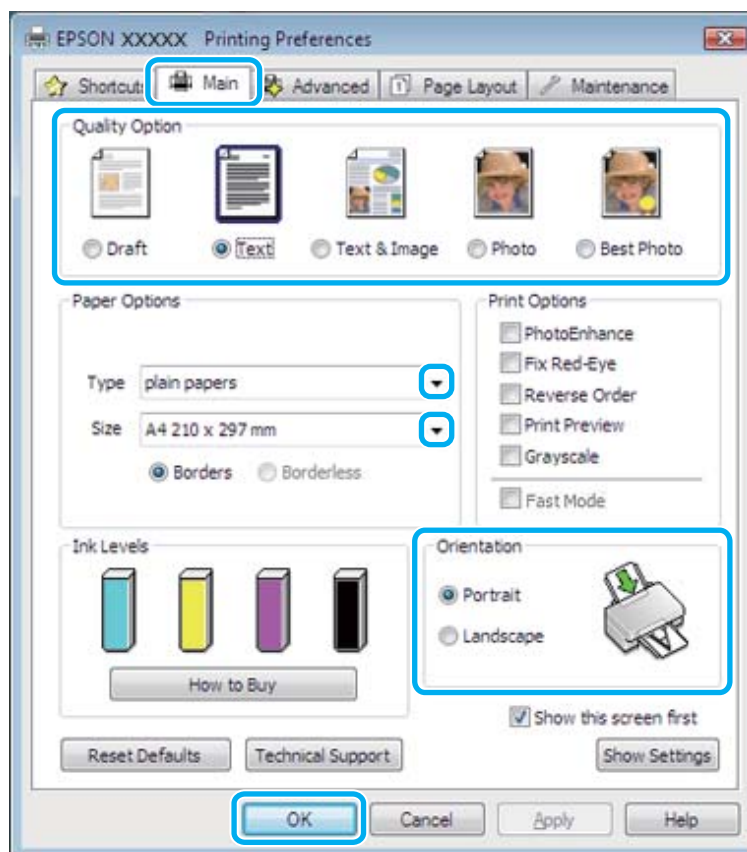

- 3 Click the **Main** tab.

Printing

- 4 Select the appropriate Type setting.
➔ “Paper type settings from the printer driver” on page 22

Note:
Print quality is automatically adjusted for the selected paper type setting.

- 5 Select **Borderless** if you want to print borderless photos.
➔ “Selecting Paper” on page 20

If you want to control the amount of the image that extends beyond the edges of the paper, click the **Page Layout** tab, select **Auto Expand** as the Enlargement Method, and then adjust the **Expansion** slider.

- 6 Select the appropriate Size setting. You can also define a custom paper size. For details, see the online help.

- 7 Select **Portrait** (tall) or **Landscape** (wide) to change the orientation of your printout.

Note:
*Select **Landscape** when printing on envelopes.*

- 8 Click **OK** to close the printer settings window.

Note:
To make changes to advanced settings, refer to the relevant section.

- 9 Print your file.

Basic product settings for Mac OS X

Note:
Screen shots of the printer driver windows in this manual are from Mac OS X 10.7.

- 1 Open the file you want to print.

Printing

- 2 Access the Print dialog box.
 ➔ “Accessing the printer driver for Mac OS X” on page 37

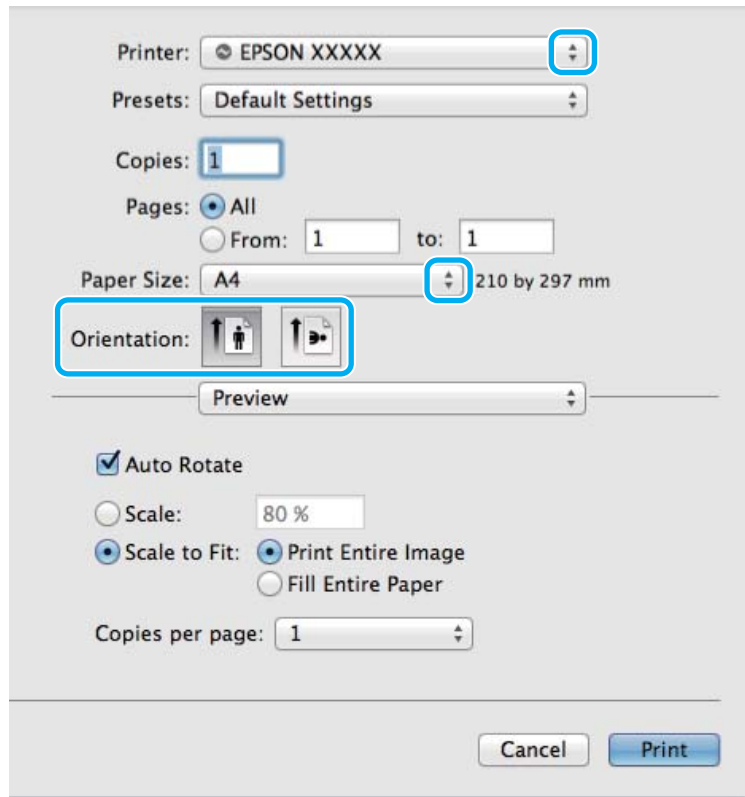

Note:

If the simplified dialog box is displayed, click the **Show Details** button (for Mac OS X 10.8 or 10.7) or the ▼ button (for Mac OS X 10.6 or 10.5) to extend this dialog box.

- 3 Select the product you are using as the Printer setting.

Note:

Depending on your application, you may not be able to select some of the items in this dialog box. If so, click **Page Setup** on the File menu of your application, and then make suitable settings.

- 4 Select the appropriate Paper Size setting.

Note:

Select **XXX (Borderless)** as the Paper Size if you want to print borderless photos.

➔ “Selecting Paper” on page 20

- 5 Select the appropriate Orientation setting.

Note:

Select landscape orientation when printing envelopes.

Printing

- 6** Select **Print Settings** from the pop-up menu.

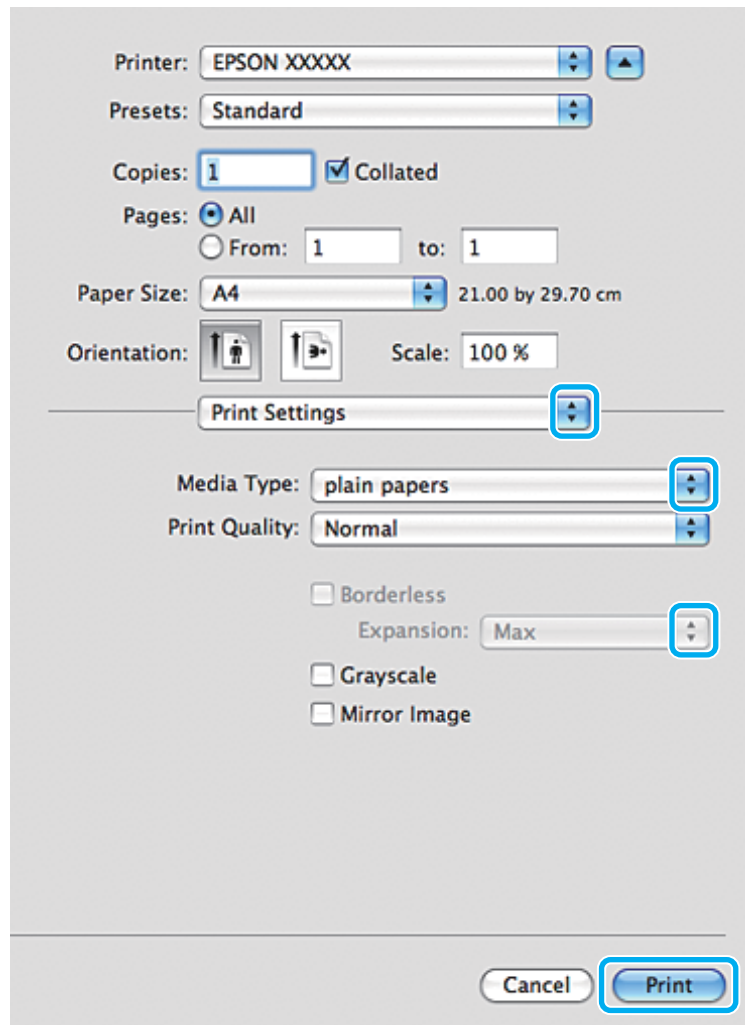

- 7** Select the appropriate Media Type setting.
 ➔ [“Paper type settings from the printer driver” on page 22](#)
- 8** Select the appropriate Expansion setting during borderless printing to control the amount of the image that extends beyond the edges of the paper.
- 9** Click **Print** to start printing.

Canceling Printing

If you need to cancel printing, follow the instructions in the appropriate section below.

Using the control panel

Press **⏻** to cancel a print job in progress.

Printing

For Windows

Note:

You cannot cancel a print job that has been completely sent to the product. In this case, cancel the print job by the product.

Using the progress meter

When you start printing, the progress meter appears on your computer screen.

Click the **Cancel** button to cancel printing.

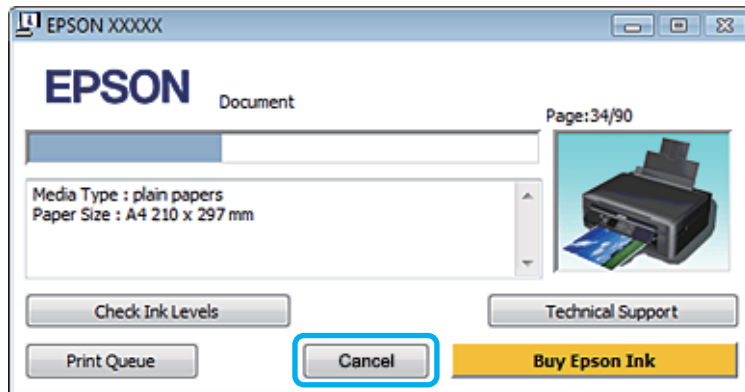

Using EPSON Status Monitor 3

- 1 Access the EPSON Status Monitor 3.
➔ [“For Windows” on page 119](#)
- 2 Click the **Print Queue** button. The Windows Spooler appears.
- 3 Right click on the job you want to cancel and then select **Cancel**.

For Mac OS X

Follow the steps below to cancel a print job.

Note:

If you have sent a print job from a Mac OS X 10.6 or 10.5 through the network, you may not be able to cancel printing from the computer. Press  on the product's control panel to cancel a print job. To solve this problem, see the online Network Guide.

- 1 Click your product icon in the Dock.
- 2 In the Document Name list, select the document which is printing.

Printing

- 3 Click the **Delete** button to cancel the print job.

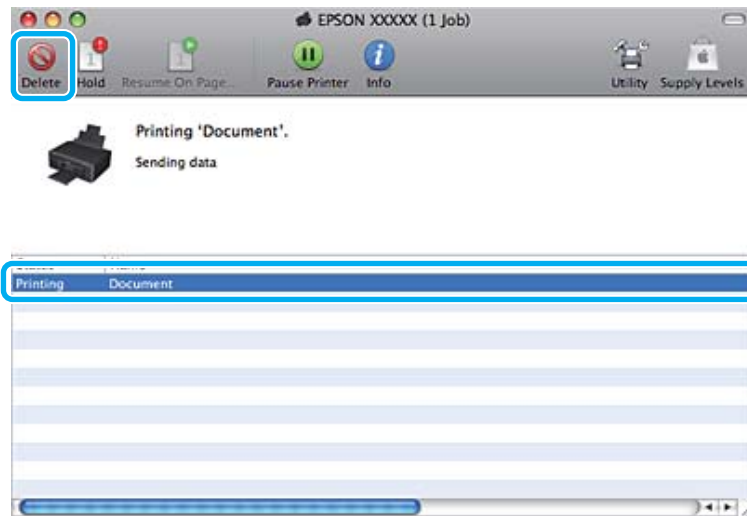

For Mac OS X 10.8:
Click the  button to cancel the print job.

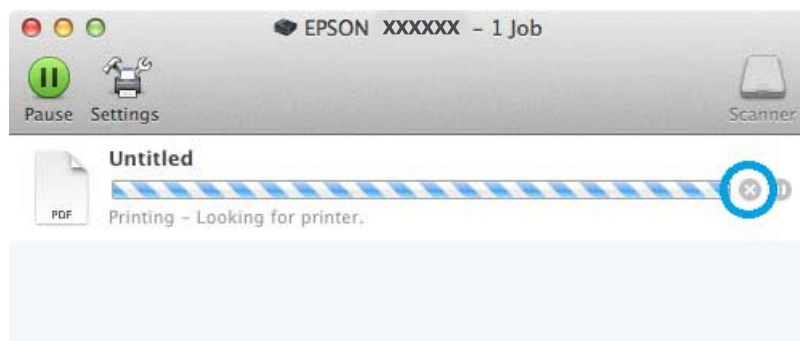

Other Options

Printing photos the easy way



Epson Easy Photo Print lets you lay out and print digital images on various types of paper. The step-by-step instructions in the window let you preview the printed images and get the effects you want without having to make any difficult settings.

Using the Quick Print function, you can perform one-click printing with the settings you make.

Starting Epson Easy Photo Print

For Windows

- ❑ Double-click the **Epson Easy Photo Print** icon on the desktop.
- ❑ **For Windows 8:**
Select **All apps**, and then select **Easy Photo Print** from **Epson Software**.

For Windows 7 and Vista:

Click the start button, point to **All Programs**, click **Epson Software**, and then click **Easy Photo Print**.

For Windows XP:

Click **Start**, point to **All Programs**, point to **Epson Software**, then click **Easy Photo Print**.

For Mac OS X

Double-click the **Applications** folder on your Mac OS X hard drive, then double-click in turn on the **Epson Software** and **Easy Photo Print** folders and finally double-click the **Easy Photo Print** icon.

Product presets (for Windows only)

Printer driver presets make printing a snap. You can also create presets of your own.

Product settings for Windows

- 1 Access the printer settings.
➔ [“Accessing the printer driver for Windows” on page 36](#)
- 2 Select a Printing Presets in the Shortcuts tab. Product settings are automatically set to the values displayed in the pop-up window.

2-sided printing (for Windows only)

Use the printer driver to print on both sides of the paper.

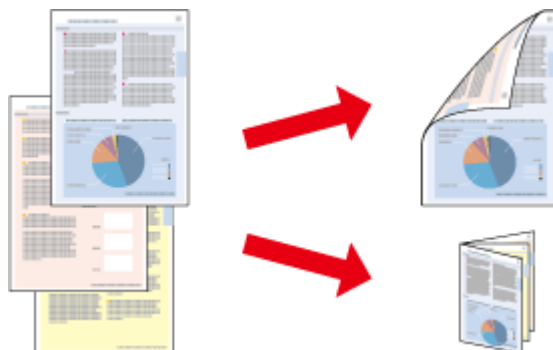

Two types of 2-sided printing are available: standard and folded booklet.

2-sided printing is only available for the following papers and sizes.

Printing

Paper	Size
Plain paper	Legal, Letter, A4, B5, A5, A6
Epson Bright White Ink Jet Paper	A4

Note:

- This feature is not available for Mac OS X.
- This feature may not be available at some settings.
- This feature may not be available when the product is accessed over a network or is used as a shared printer.
- The loading capacity differs during 2-sided printing.
➔ [“Selecting Paper” on page 20](#)
- Only use papers that are suitable for 2-sided printing. Otherwise, the printout quality may deteriorate.
- Depending on the paper and the amount of ink used to print text and images, ink may bleed through to the other side of the paper.
- The surface of the paper may be smeared during 2-sided printing.
- This feature is available only when EPSON Status Monitor 3 is enabled. To enable the status monitor, access the printer driver and click the **Maintenance** tab followed by the **Extended Settings** button. In the Extended Settings window, check the **Enable EPSON Status Monitor 3** check box.

Product settings for Windows

- 1** Access the printer settings.
➔ [“Accessing the printer driver for Windows” on page 36](#)
- 2** Choose the desired 2-sided printing option in the Page Layout tab. To print folded booklets, select **Folded Booklet**.
- 3** Check the other settings and print.

Note:

- The actual binding margin may be different from the specified settings depending on your application. Experiment with a few sheets to examine actual results before printing the entire job.
- Make sure that the ink is completely dry before reloading the paper.

Fit to page printing

Lets you automatically enlarge or reduce the size of your document to fit the paper size selected in the printer driver.

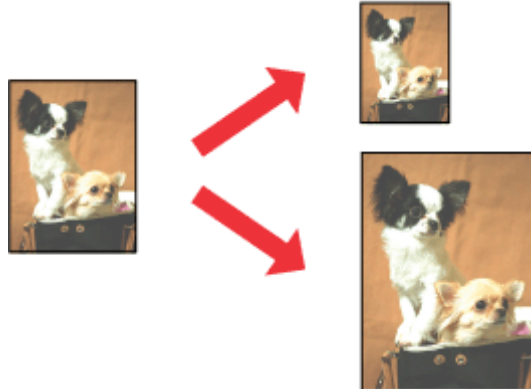
**Note:**

This feature may not be available at some settings.

Product settings for Windows

- 1 Access the printer settings.
➔ [“Accessing the printer driver for Windows” on page 36](#)
- 2 Select **Reduce/Enlarge Document** and **By Output Paper Size** in the Page Layout tab, and then select the size of the paper you are using from the drop-down list.
- 3 Check the other settings and print.

Product settings for Mac OS X

- 1 Access the Print dialog box.
➔ [“Accessing the printer driver for Mac OS X” on page 37](#)
- 2 Choose **Scale to fit paper size** for Destination Paper Size in the Paper Handling pane, and then select the size of the paper you are using from the pop-up menu.
- 3 Check the other settings and print.

Pages per sheet printing

Lets you use the printer driver to print two or four pages on a single sheet of paper.

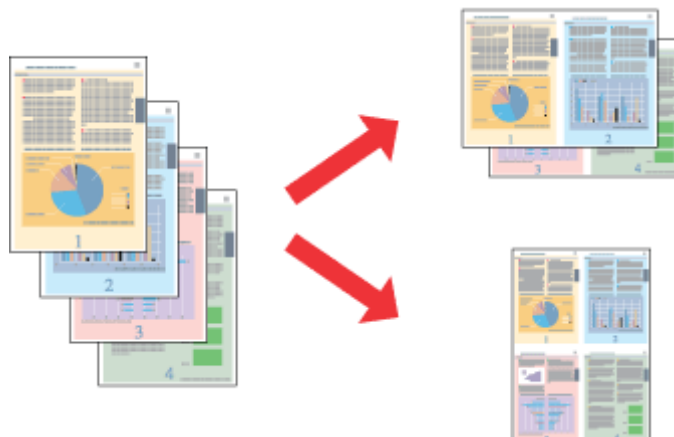
**Note:**

This feature may not be available at some settings.

Product settings for Windows

- 1 Access the printer settings.
➔ [“Accessing the printer driver for Windows” on page 36](#)
- 2 Select **Multi-Page** and then select the **Pages per Sheet** in the Page Layout tab.
- 3 Choose the desired number of pages and page order.
- 4 Check the other settings and print.

Product settings for Mac OS X

- 1 Access the Print dialog box.
➔ [“Accessing the printer driver for Mac OS X” on page 37](#)
- 2 Select the desired number of Pages per Sheet and the Layout Direction (page order) in the Layout pane.
- 3 Check the other settings and print.

Sharing the Product for Printing

Setup for Windows

These instructions tell you how to set up your product so other users on the network can share it.

First you will set up the product as a shared printer on the computer directly connected to it. Then you will add the product to each network computer that will access it.

Note:

- These instructions are for small networks only. To share the product on a large network, consult your network administrator.*
- The screen shots in the following section are from Windows 7.*

Setting up the product as a shared printer

Note:

- To set up the product as a shared printer in Windows 8, 7 or Vista, you will need an account with administrator privileges and the password if you log on as a standard user.*
- To set up the product as a shared printer in Windows XP, you must log on to a Computer Administrator account.*

Follow the steps below on the computer that is connected directly to the product:

1**Windows 8:**

Select **Control Panel** from **Settings**. Then select **Devices and Printers** from the **Hardware and Sound** category.

Windows 7:

Click the start button, select **Devices and Printers**.

Windows Vista:

Click the start button, select **Control Panel**, and then select **Printer** from the **Hardware and Sound** category.

Windows XP:

Click **Start** and select **Control Panel**, and then select **Printers and Faxes**, from the **Printers and Other Hardware** category.

2**Windows 8 and 7:**

Right-click on the product, or press and hold the product, and select **Printer properties**, and then select **Sharing**. Then select the **Change Sharing Options** button.

Windows Vista:

Right-click the icon for your product, and then click **Sharing**. Click the **Change sharing options** button and then click **Continue**.

Windows XP:

Right-click the icon for your product, then click **Sharing**.

Printing

- 3** Select **Share this printer**, then type a Share name.

Note:

Do not use spaces or hyphens in the share name.

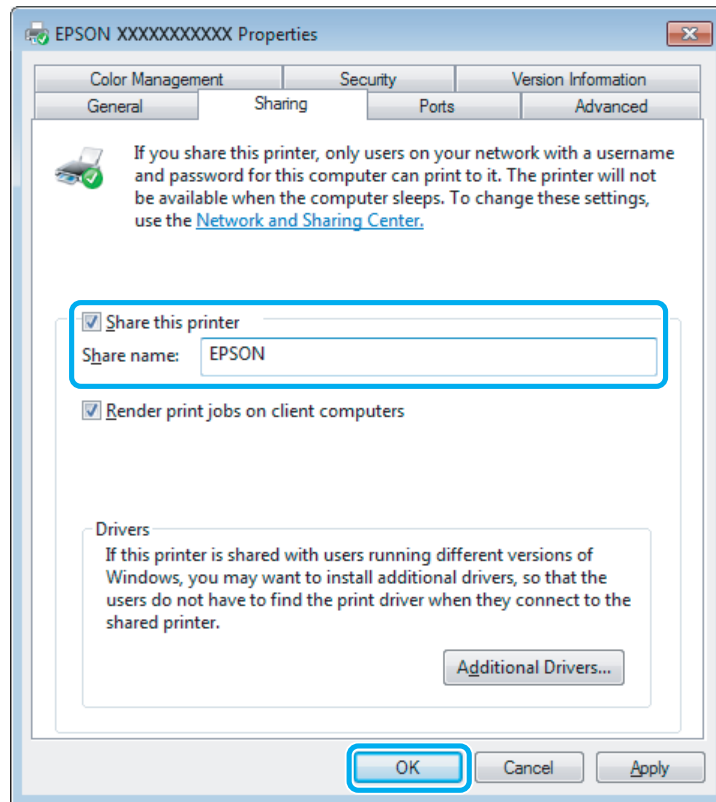

If you want to automatically download printer drivers for computers that are running different versions of Windows, click **Additional Drivers** and select the environment and the operating systems of the other computers. Click **OK**, then insert the product software disk.

- 4** Click **OK** or **Close** (if you installed additional drivers).

Adding the product to the other network computers

Follow these steps to add the product to each network computer that will access it.

Note:

Your product must be set up as a shared printer on the computer to which it is connected before you can access it from another computer.

➔ [“Setting up the product as a shared printer” on page 48](#)

- 1 Windows 8:**
Select **Control Panel** from **Settings**. Then select **Devices and Printers** from the **Hardware and Sound** category.

Windows 7:

Click the start button, select **Devices and Printers**.

Printing

Windows Vista:

Click the start button, select **Control Panel**, and then select **Printer** from the **Hardware and Sound** category.

Windows XP:

Click **Start** and select **Control Panel**, and then select **Printers and Faxes**, from the **Printers and Other Hardware** category.

- 2** **Windows 8, 7 and Vista:**
Select the **Add a printer** button.

Windows XP:

Click the **Add a printer** button. The Add Printer Wizard appears. Click the **Next** button.

- 3** **Windows 8:**
Go to Step 4.

Windows 7 and Vista:

Click **Add a network, wireless or Bluetooth printer**, and then click **Next**.

Windows XP:

Select **A network printer, or a printer attached to another computer**, then click **Next**.

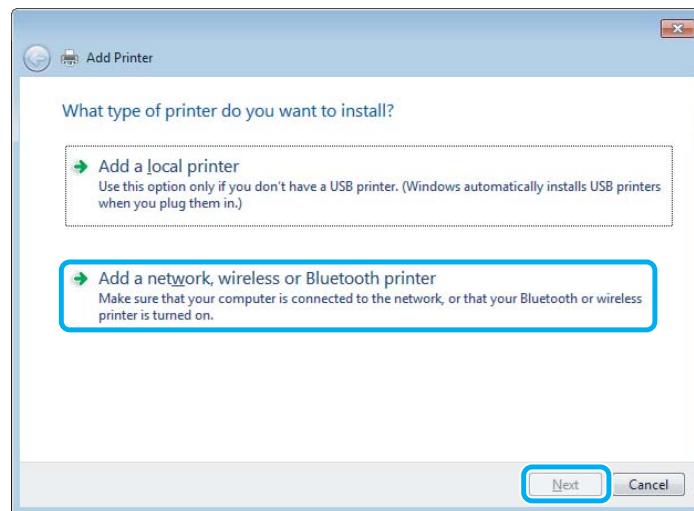

- 4** Follow the on-screen instructions to select the product you want to use.

Note:

Depending on the operating system and the configuration of the computer to which the product is connected, the Add Printer Wizard may prompt you to install the printer driver from the product software disk. Click the **Have Disk** button and follow the on-screen instructions.

Setup for Mac OS X

To set up your product on a Mac OS X network, use the Printer Sharing setting. See your Macintosh documentation for details.

Scanning

Let's Try Scanning

Starting a Scan

Let's scan a document to get used to the process.

- 1 Place your original(s) on the scanner glass.
➔ [“Placing Originals” on page 28](#)
- 2 Start Epson Scan.
 - Windows 8:
Select the **EPSON Scan** icon on the desktop, or select **EPSON Scan** from the **Start** screen.
 - Windows 7, Vista and XP:
Double-click the **Epson Scan** icon on the desktop.
 - Mac OS X:
Select **Applications > Epson Software > EPSON Scan**.
- 3 Select **Home Mode**.

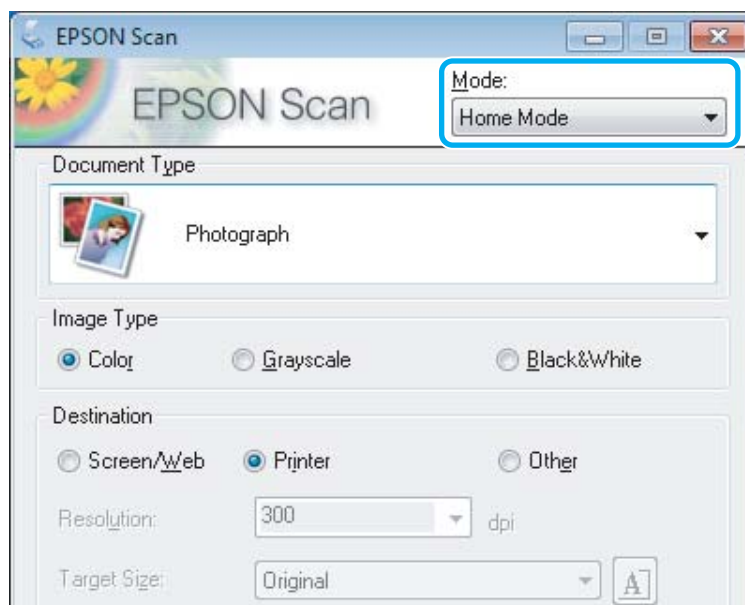

Scanning

- 4** Select **Text/Line Art** as the **Document Type** setting.

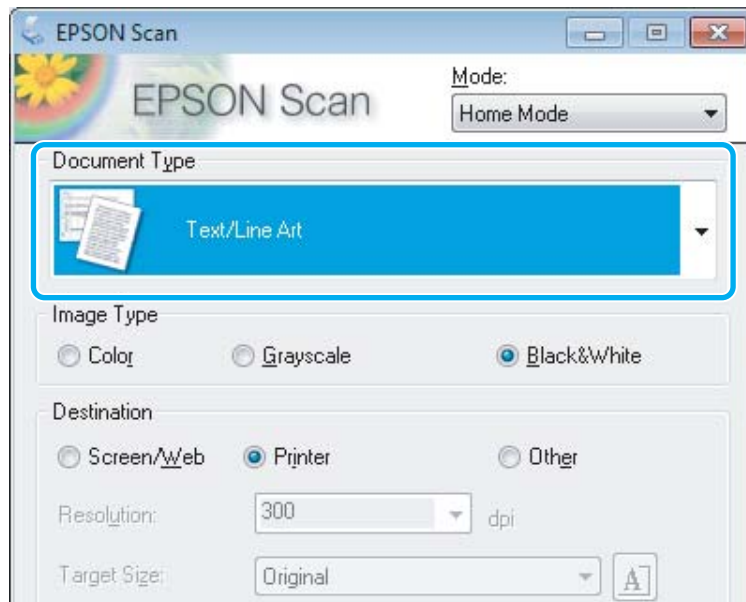

- 5** Click **Preview**.

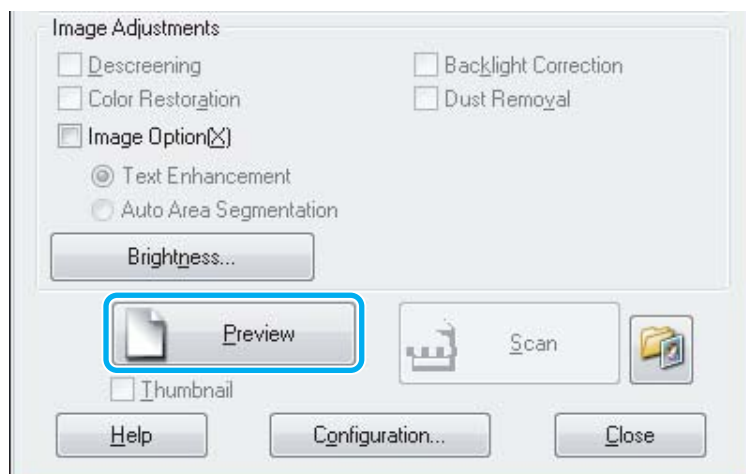

- 6** Click **Scan**.

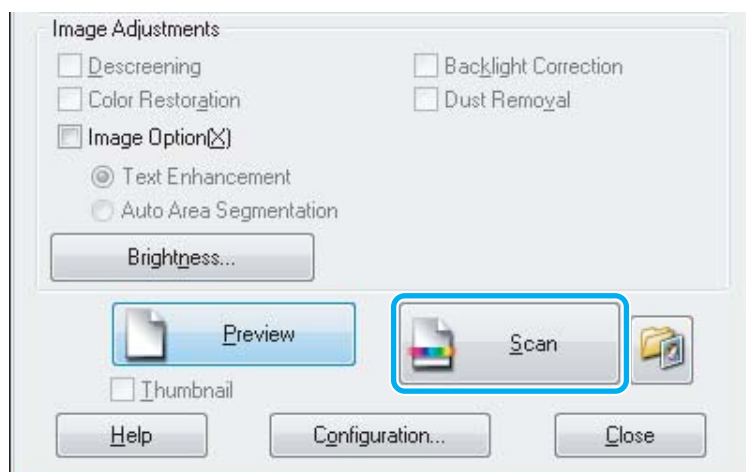

Scanning

7 Click OK.

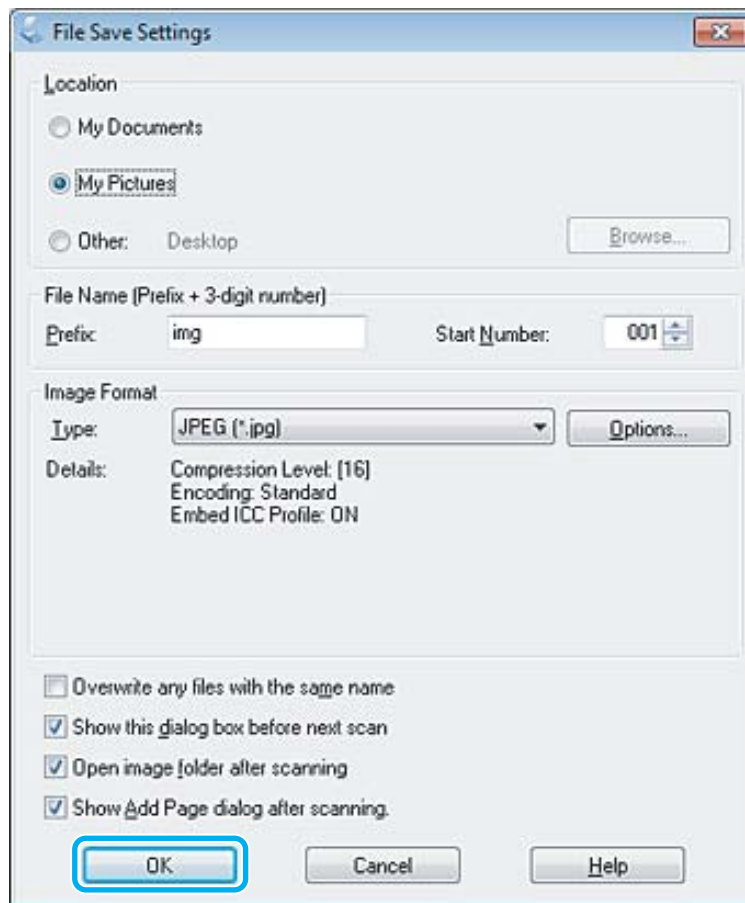

Your scanned image is saved.



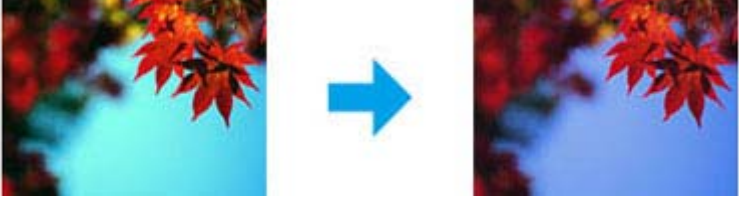



Image Adjustment Features

Epson Scan offers a variety of settings for improving color, sharpness, contrast, and other aspects affecting image quality.





See the Help for more details on Epson Scan.

Histogram	<p>Provides a graphical interface for adjusting highlight, shadow, and gamma levels individually.</p> 
-----------	--

Scanning

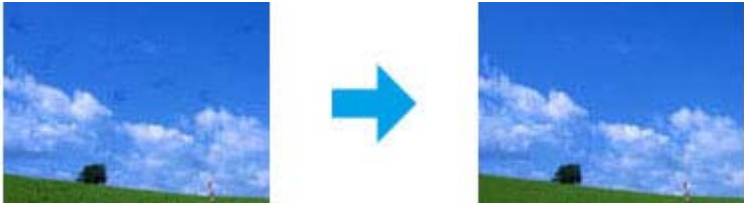
<p>Tone Correction</p>	<p>Provides a graphical interface for adjusting tone levels individually.</p> 
<p>Image Adjustment</p>	<p>Adjusts brightness and contrast and the balance of red, green, and blue colors in the overall image.</p> 
<p>Color Palette</p>	<p>Provides a graphical interface for adjusting mid-tone levels, such as skin tones, without affecting the highlight and shadow areas of the image.</p> 
<p>Unsharp Mask</p>	<p>Sharpens the edges of image areas for an overall clearer image.</p> 
<p>Descreening</p>	<p>Removes rippled patterns (known as moiré) that can appear in subtly shaded image areas such as skin tones.</p> 
<p>Color Restoration</p>	<p>Restores the colors in faded photos automatically.</p> 

Scanning

<p>Backlight Correction</p>	<p>Removes shadows from photos that have too much background light.</p> 
<p>Dust Removal</p>	<p>Removes dust marks from your originals automatically.</p> 
<p>Text Enhancement</p>	<p>Enhances text recognition when scanning text documents.</p> 
<p>Auto Area Segmentation</p>	<p>Makes Black&White images clearer and text recognition more accurate by separating the text from the graphics.</p> 
<p>Color Enhance</p>	<p>Enhance a certain color. You can select from red, blue, or green.</p> 

Basic Scanning from the Control Panel

You can scan documents and send the scanned image from the product to a connected computer. Make sure you have installed software for the product on your computer and connected to the computer.

For XP-310 Series/XP-410 Series

Note for XP-410 Series:

If you want to scan your data to a memory card, insert a memory card first.

➔ [“Inserting a Memory Card” on page 26](#)

- 1** Place your original on the scanner glass.
➔ [“Placing Originals” on page 28](#)
- 2** Enter the **Scan** mode from the **Home** menu.
- 3** Select a scan menu item. Use ◀ or ▶ to select a menu, and press **OK**.
➔ [“Scan Mode” on page 75](#)
- 4** If you select **Scan to PC**, select your computer. If you select **Scan to Memory Card**, make scanning settings such as saving format and scan area.

Note:

- If the product is connected to a network, you can select the computer to which you want to save the scanned image.
- You can change the computer name displayed on the control panel using Epson Event Manager.
- For XP-410 Series: If you want to use the **Scan to Cloud** service, see the Epson Connect guide, which is available on the Epson Connect portal site.
➔ [“Using Epson Connect Service” on page 8](#)

- 5** Press ◊ to start scanning.

Your scanned image is saved.

For XP-210 Series

- 1** Place your original on the scanner glass.
➔ [“Placing Originals” on page 28](#)
- 2** Press the two start buttons simultaneously.

Your scanned image is saved in PDF format on your computer.

Scan mode menu list

Refer to the section below for the Scan mode menu list.

➔ [“Scan Mode” on page 75](#)

Basic Scanning from Your Computer

Scanning in Full Auto Mode

Full Auto Mode lets you scan quickly and easily, without selecting any settings or previewing your image. This mode is useful when you need to scan your originals at 100% size.

Note:

- This mode is not available when the Automatic Document Feeder is installed.
- See the Help for more details on Epson Scan.

- 1 Place your original(s).
- 2 Start Epson Scan.
➔ [“Starting Epson Scan Driver” on page 71](#)
- 3 Select **Full Auto Mode** from the Mode list.

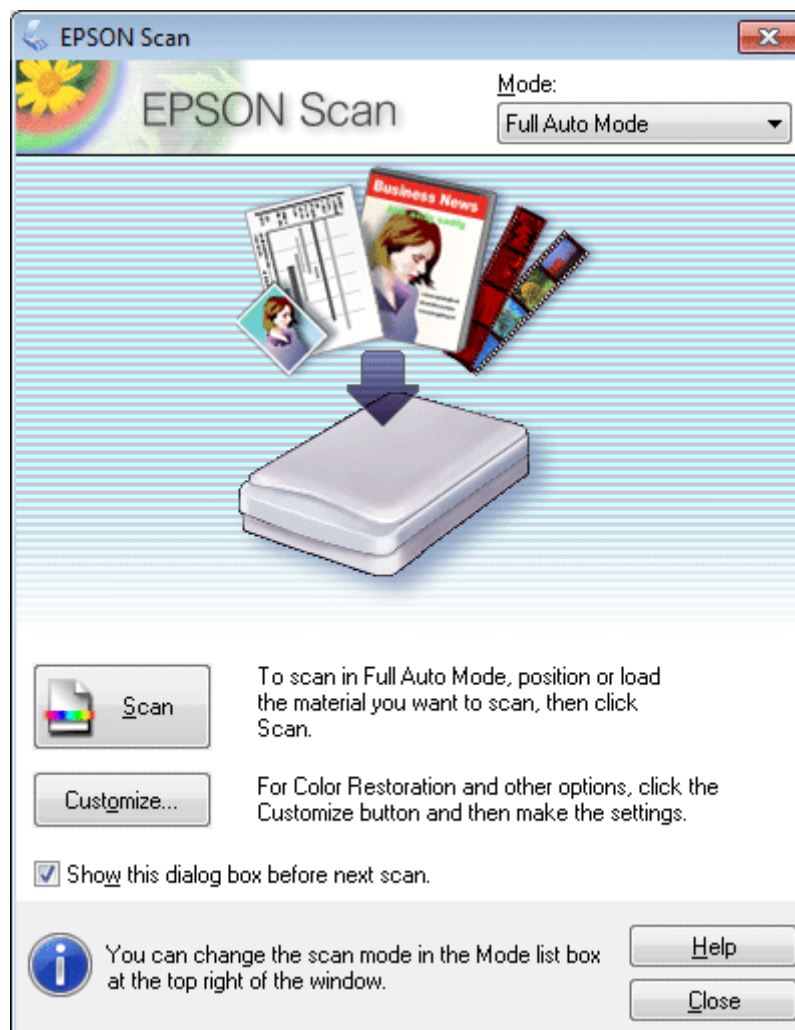

Scanning

Note:

If the **Show this dialog box before next scan** check box is cleared, Epson Scan starts scanning immediately without displaying this screen. To return to this screen, click **Cancel** in the Scanning dialog box during scanning.

4

Click **Scan**. Epson Scan starts scanning in Full Auto Mode.

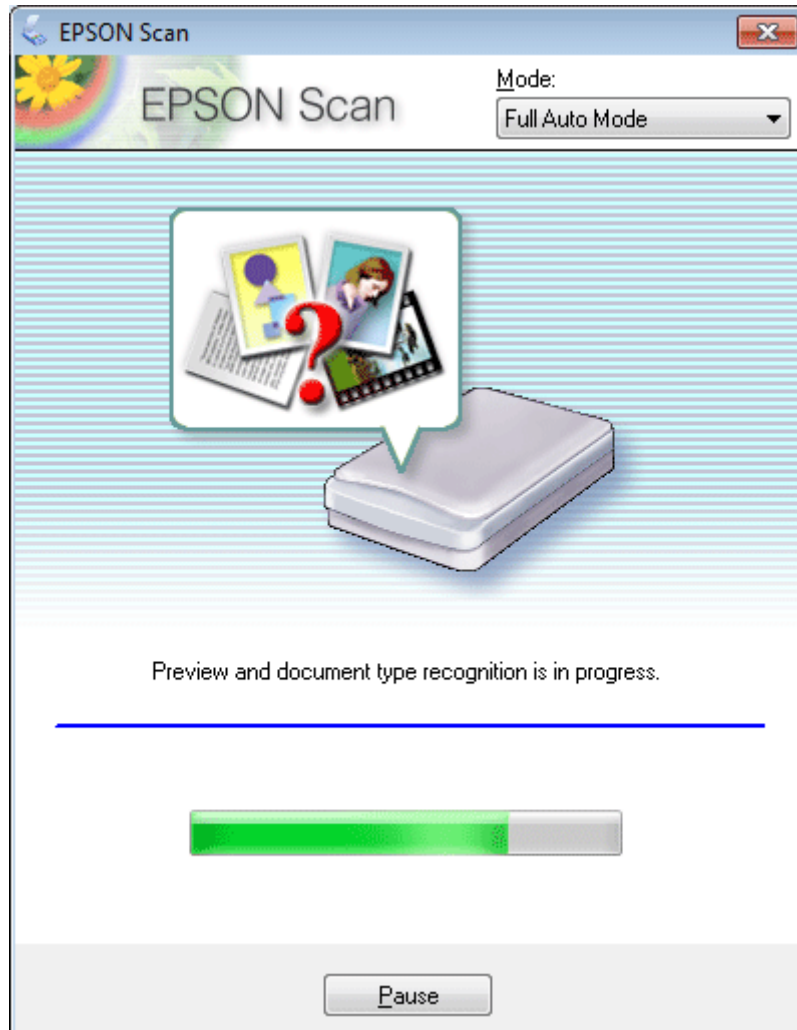

Epson Scan previews each image, detects what type of original it is, and selects the scan settings automatically.

Your scanned image is saved.

Scanning in Home Mode

Home Mode lets you customize some scanning settings and check the changes you have made in a preview image. This mode is useful for basic scanning of photos and graphics.

Note:

- In Home Mode, you can only scan from the scanner glass.
- See the Help for more details on Epson Scan.

Scanning

- 1 Place your original(s).
➔ “Placing Originals” on page 28
- 2 Start Epson Scan.
➔ “Starting Epson Scan Driver” on page 71
- 3 Select **Home Mode** from the Mode list.

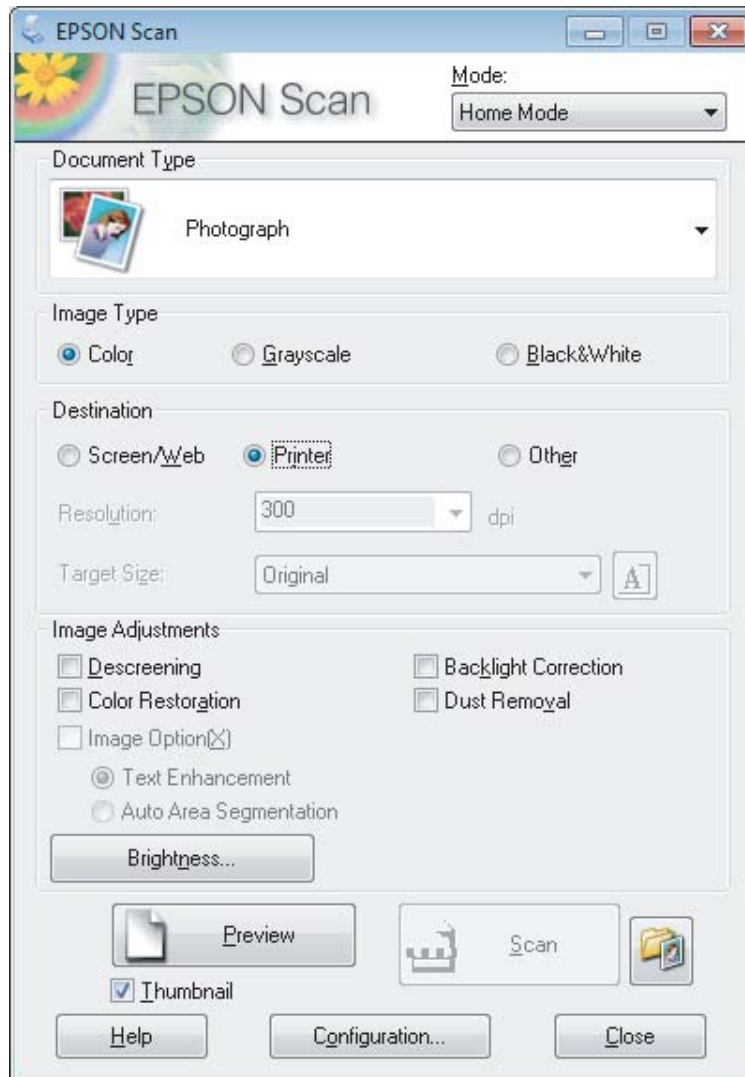

- 4 Select the Document Type setting.
- 5 Select the Image Type setting.
- 6 Click **Preview**.
➔ “Previewing and Adjusting the Scan Area” on page 64
- 7 Adjust the exposure, brightness, and other image quality settings.
- 8 Click **Scan**.

Scanning

- 9 In the File Save Settings window, select the Type setting and then click **OK**.

Note:

If the **Show this dialog box before next scan** check box is cleared, Epson Scan starts scanning immediately without displaying the File Save Settings window.

Your scanned image is saved.

Scanning in Office Mode

Office Mode lets you quickly scan text documents without previewing your image.

Note:

See the *Help* for more details on Epson Scan.

- 1 Place your original(s).
➔ [“Placing Originals” on page 28](#)
- 2 Start Epson Scan.
➔ [“Starting Epson Scan Driver” on page 71](#)

Scanning

- 3 Select **Office Mode** from the Mode list.

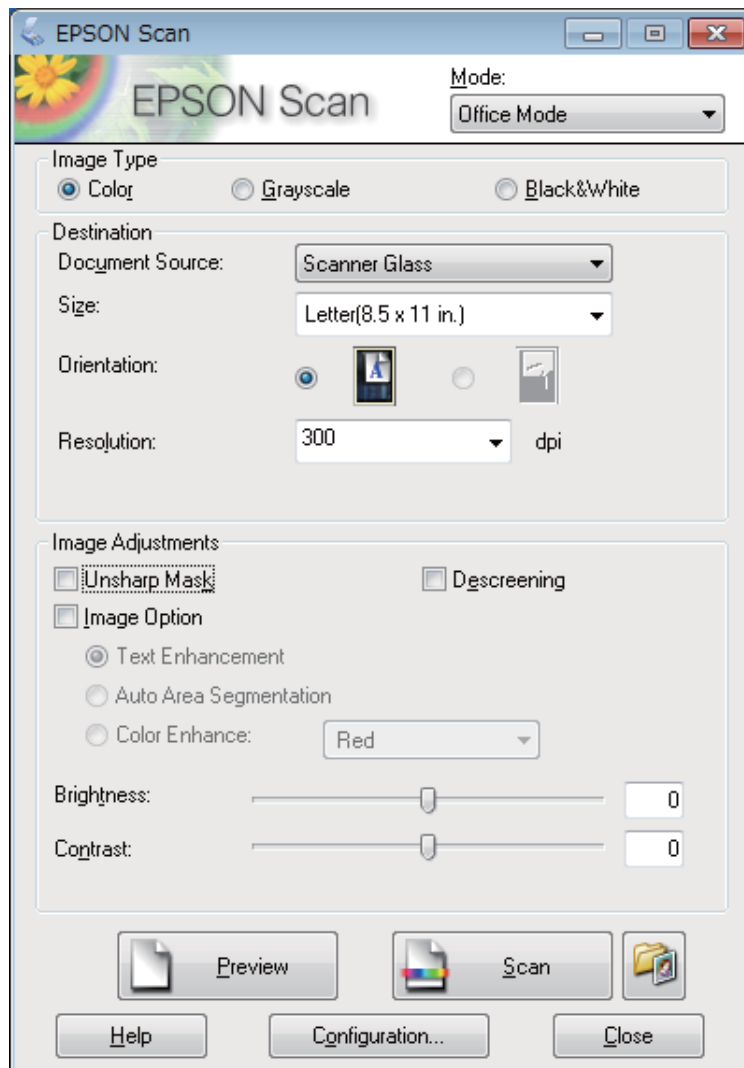

- 4 Select the Image Type setting.
- 5 Select the Document Source setting.
- 6 Select the size of your original as the Size setting.
- 7 Select an appropriate resolution for your original(s) as the Resolution setting.
- 8 Click **Scan**.

Scanning

- 9 In the File Save Settings window, select the Type setting and then click **OK**.

Note:

If the **Show this dialog box before next scan** check box is cleared, Epson Scan starts scanning immediately without displaying the File Save Settings window.

Your scanned image is saved.

Scanning in Professional Mode

Professional Mode gives you total control of your scanning settings and lets you check the changes you have made in a preview image. This mode is recommended for advanced users.

Note:

See the *Help* for more details on Epson Scan.

- 1 Place your original(s).
➔ [“Placing Originals” on page 28](#)
- 2 Start Epson Scan.
➔ [“Starting Epson Scan Driver” on page 71](#)

Scanning

- 3 Select **Professional Mode** from the Mode list.

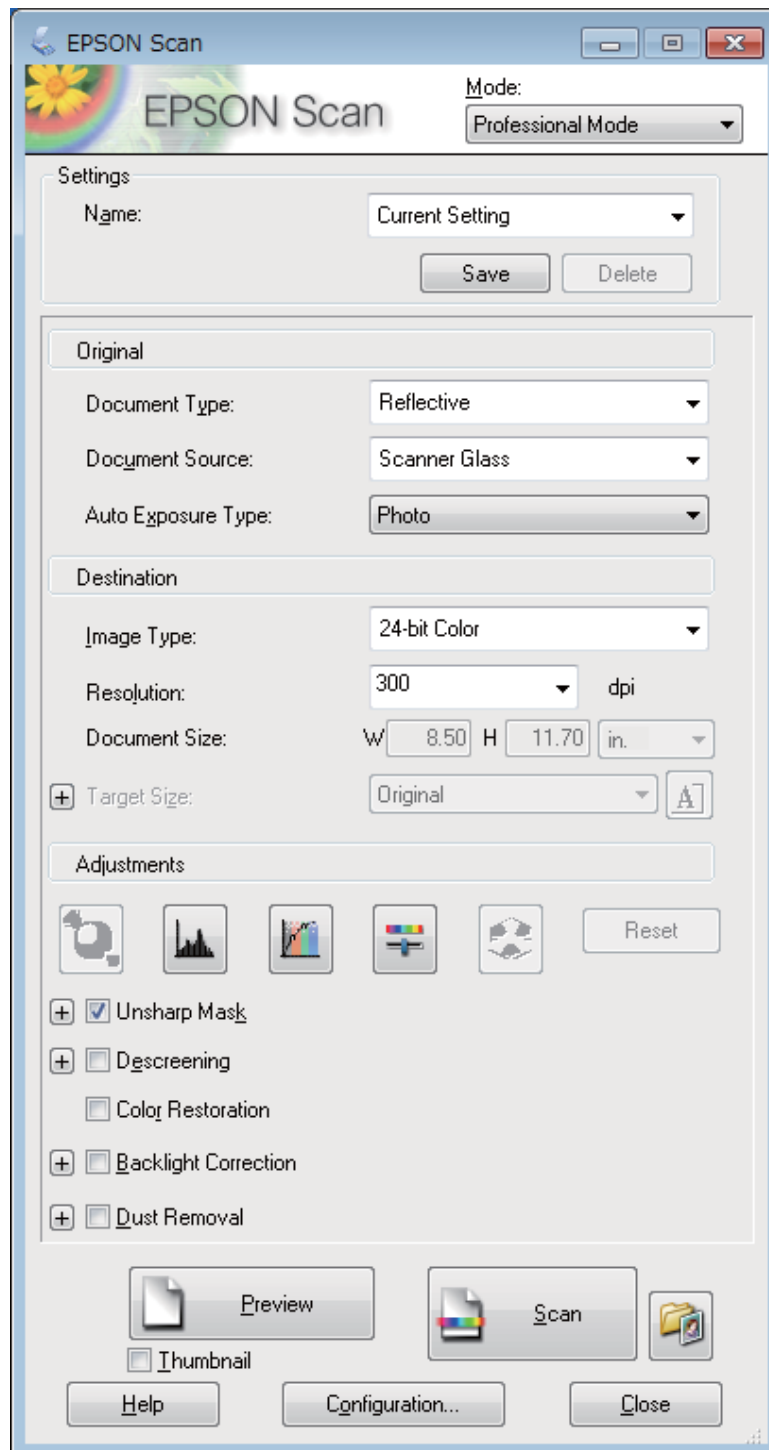

- 4 Select the type of original(s) you are scanning as the Document Type setting.

- 5 Select the Document Source setting.

- 6 If you select **Reflective** as the Document Type setting, select **Photo** or **Document** as the Auto Exposure Type setting.

Scanning

- 7 Select the Image Type setting.
- 8 Select an appropriate resolution for your original(s) as the Resolution setting.
- 9 Click **Preview** to preview your image(s). The Preview window opens and displays your image(s).
➔ [“Previewing and Adjusting the Scan Area” on page 64](#)
- 10 Select the size of the scanned image(s) as the Target Size setting if necessary. You can scan your images at their original size, or you can reduce or enlarge their size by selecting Target Size.
- 11 Adjust the image quality if necessary.
➔ [“Image Adjustment Features” on page 53](#)

Note:

You can save the settings you make as a group of custom settings with a **Name**, and later apply these custom settings when scanning. Your custom settings are also available in Epson Event Manager.

See the Help for more details on Epson Event Manager.

- 12 Click **Scan**.
- 13 In the File Save Settings window, select the Type setting and then click **OK**.

Note:

If the **Show this dialog box before next scan** check box is cleared, Epson Scan starts scanning immediately without displaying the File Save Settings window.

Your scanned image is saved.

Previewing and Adjusting the Scan Area

Selecting a preview mode

Once you have selected your basic settings and resolution, you can preview your image and select or adjust the image area in a Preview window. There are two types of preview.

- Normal preview displays your previewed image(s) in their entirety. You can select the scan area and make any image quality adjustments manually.
- Thumbnail preview displays your previewed image(s) as thumbnail(s). Epson Scan automatically locates the edges of your scan area, applies automatic exposure settings to the image(s), and rotates the image(s) if necessary.

Scanning

Note:

- ❑ Some of the settings that you change after previewing an image are reset if you change the preview mode.
- ❑ Depending on your document type and the Epson Scan mode you are using, you may not be able to change the preview type.
- ❑ If you preview image(s) without the Preview dialog displayed, image(s) are displayed in the default preview mode. If you preview with the Preview dialog displayed, image(s) are displayed in the preview mode that was displayed just before previewing.
- ❑ To resize the Preview window, click and drag the corner of the Preview window.
- ❑ See the Help for more details on Epson Scan.

Creating a marquee

A marquee is a moving dotted line that appears on the edges of your preview image to indicate the scan area.

Do one of the following to draw a marquee.



- ❑ To draw the marquee manually, position the pointer in the area where you want to place the corner of your marquee and click. Drag the cross-hairs over the image to the opposite corner of the desired scan area.





- ❑ To draw the marquee automatically, click the  auto locate icon. You can only use this icon when you are viewing a normal preview and you only have one document on the scanner glass.
- ❑ To draw the marquee at a specified size, type in a new width and height in the Document Size setting.
- ❑ For best results and image exposure, make sure all sides of the marquee are located inside the preview image. Do not include any areas around the preview image in the marquee.

Adjusting a marquee

You can move the marquee and adjust its size. If you are viewing a normal preview, you can create multiple marquees (up to 50) on each image to scan different image areas as separate scan files.

	To move the marquee, position your cursor inside the marquee. The pointer becomes a hand. Click and drag the marquee to the desired location.
	To resize the marquee, position your cursor over the edge or corner of the marquee. The pointer becomes a straight or angled double-arrow. Click and drag the edge or corner to the desired size.

Scanning

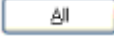
	To create additional marquees of the same size, click this icon.
	To delete a marquee, click inside the marquee and click this icon.
	To activate all marquees, click this icon.

Note:

- To restrict the movement of the marquee to vertical or horizontal only, hold down the **Shift** key as you move the marquee.
- To restrict the size of the marquee to the current proportions, hold down the **Shift** key as you resize the marquee.
- If you draw multiple marquees, make sure you click **All** in the Preview window before you scan. Otherwise, only the area inside the last marquee you drew will be scanned.

Various Types of Scanning

Scanning a Magazine

First of all, place your magazine and start Epson Scan.

➔ [“Starting a Scan” on page 51](#)

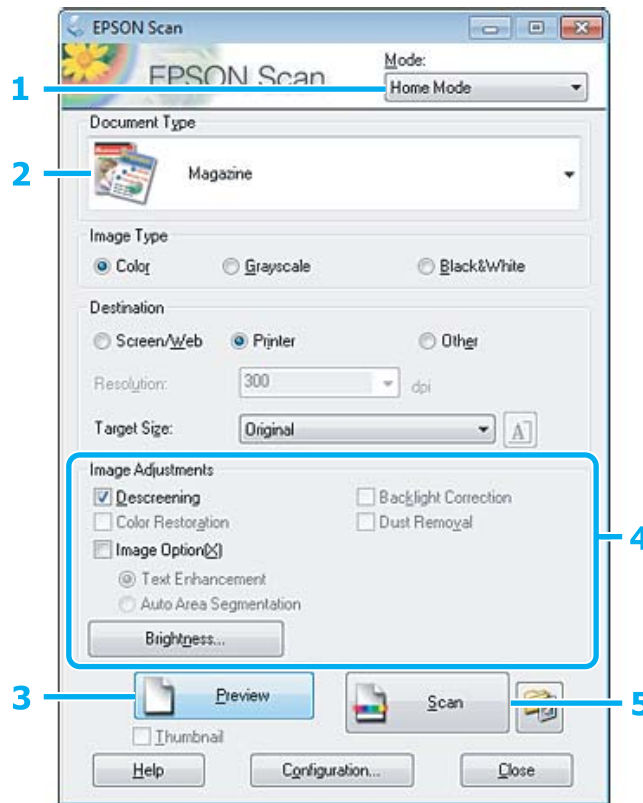

- 1** Select **Home Mode** from the Mode list.

Scanning

- 2 Select **Magazine** as the Document Type setting.
- 3 Click **Preview**.
- 4 Adjust the exposure, brightness, and other image quality settings.
See the Help for more details on Epson Scan.
- 5 Click **Scan**.

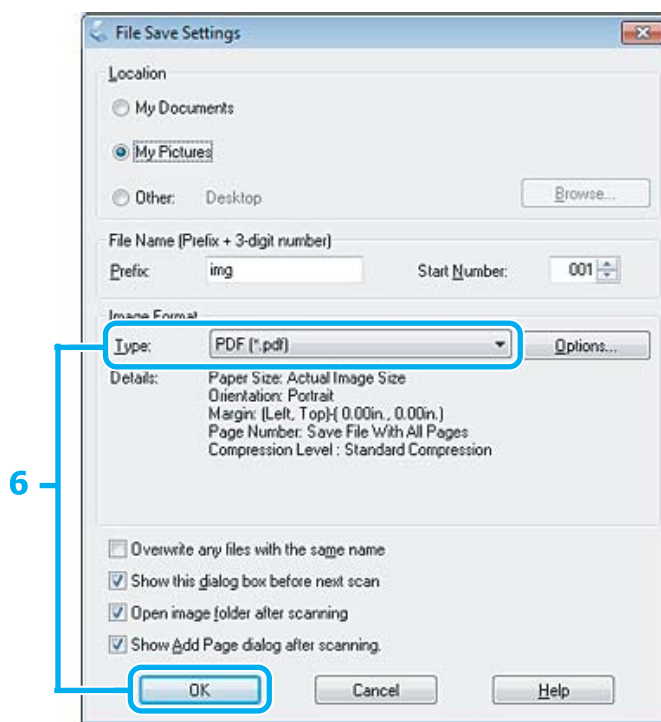

- 6 Select **PDF** as the Type setting, and then click **OK**.
Your scanned image is saved.

Scanning Multiple Documents to a PDF File

First of all, place your document and start Epson Scan.

➔ “Starting a Scan” on page 51

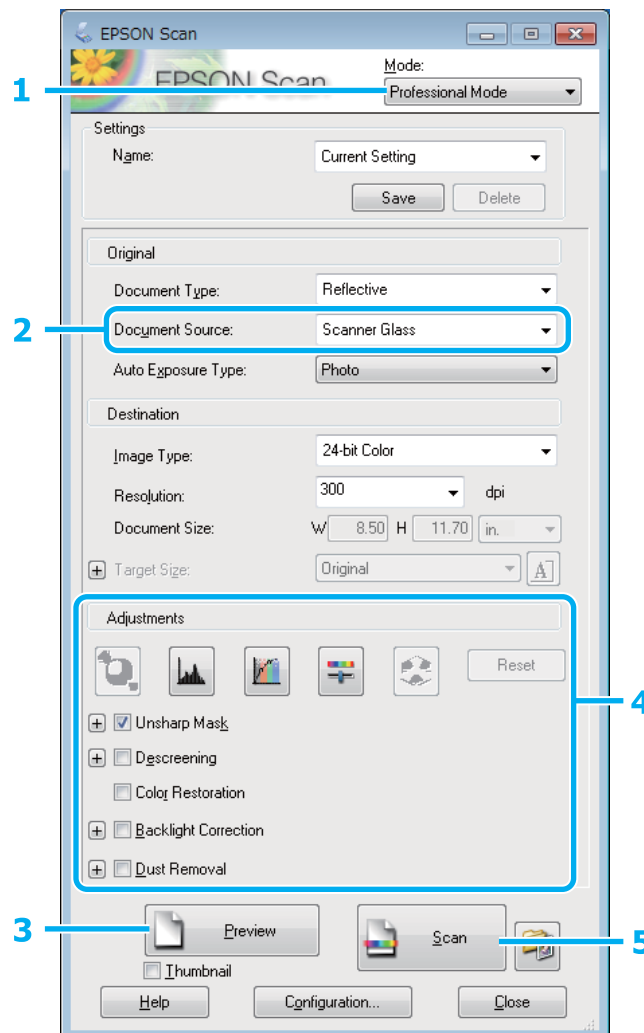

- 1 Select **Professional Mode** from the Mode list.
- 2 Select the Document Source setting.
- 3 Click **Preview**.
- 4 Adjust the exposure, brightness, and other image quality settings.
See the Help for more details on Epson Scan.

Scanning

5 Click **Scan**.

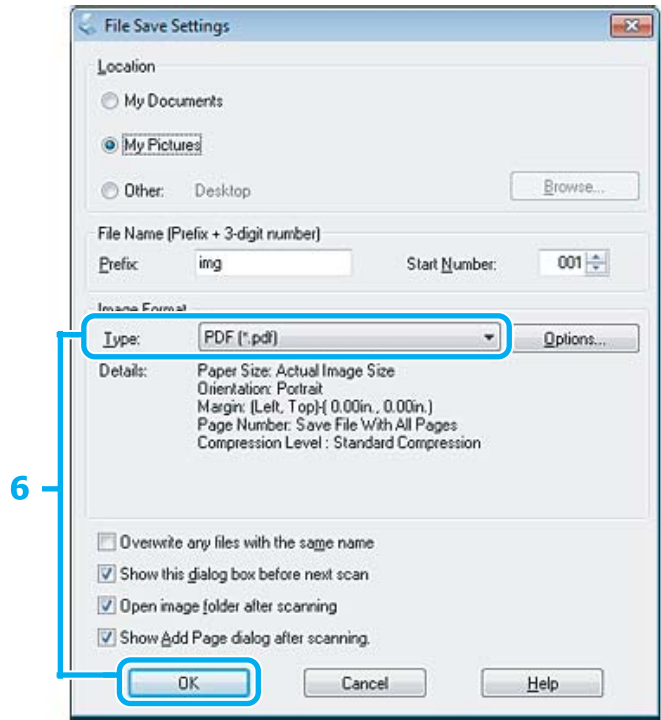

6 Select **PDF** as the Type setting, and then click **OK**.

Note:
If the **Show Add Page dialog after scanning** check box is cleared, Epson Scan automatically saves your document without displaying the Add Page Confirmation window.

7 Epson Scan starts scanning your document.

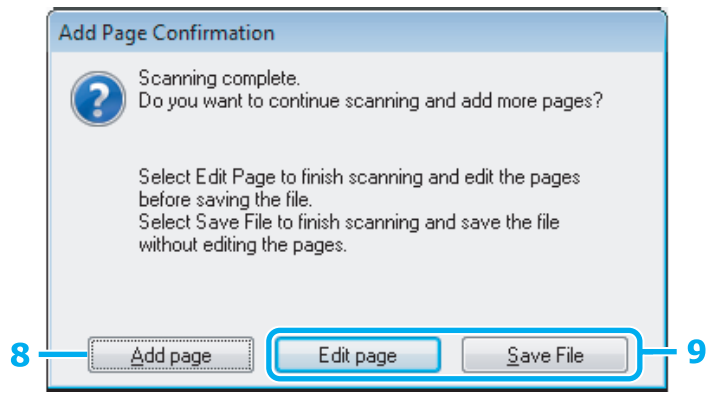

8 If you want to scan more pages, click **Add page**.
Load the document and scan again, repeating as necessary for each page.

If you have finished scanning, go to step 9.

Scanning

9 Click **Edit page** or **Save File**.

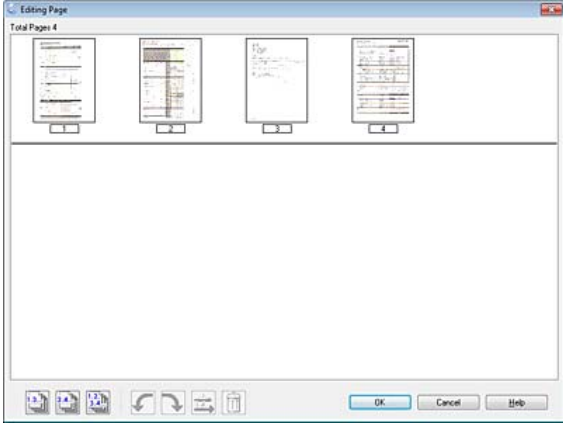
<p>Edit page</p>	<p>Select this button if you want to delete or reorder any of the pages. Then use the icons on the bottom of the Editing Page window to select, rotate, reorder, and delete pages. See the Help for more details on Epson Scan.</p>  <p>Click OK when you are finished editing your pages.</p>
<p>Save File</p>	<p>Select this button when you are finished.</p>

The pages are saved in one PDF file.

Scanning a Photo

First of all, place your photo on the scanner glass and start Epson Scan.

➔ [“Starting a Scan” on page 51](#)

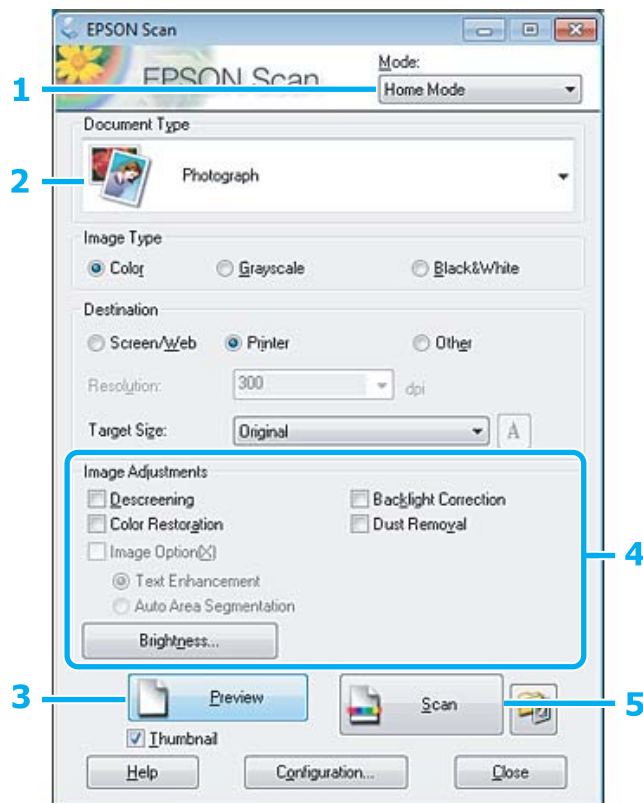

Scanning

- 1 Select **Home Mode** from the Mode list.
- 2 Select **Photograph** as the Document Type setting.
- 3 Click **Preview**.
- 4 Adjust the exposure, brightness, and other image quality settings.
See the Help for more details on Epson Scan.
- 5 Click **Scan**.

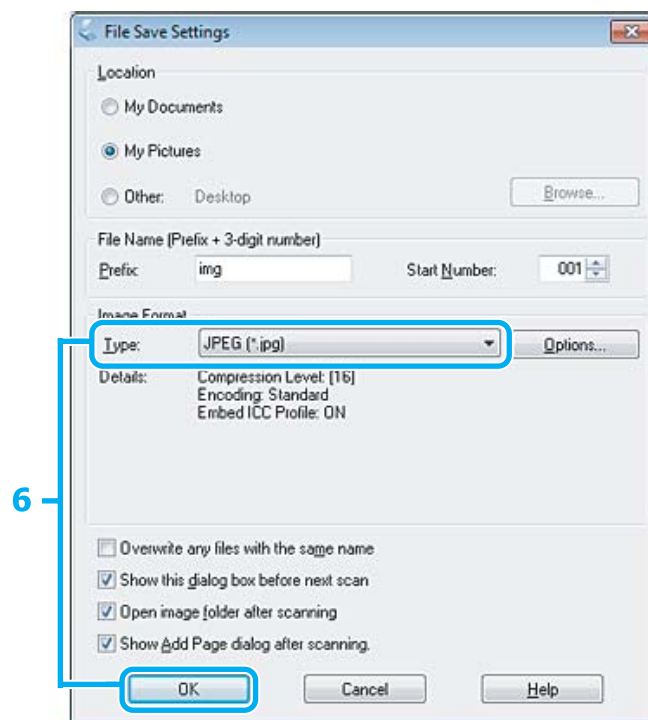

- 6 Select **JPEG** as the Type setting, and then click **OK**.

Your scanned image is saved.

Software Information

Starting Epson Scan Driver

This software lets you control all aspects of scanning. You can use this as a standalone scanning program or use it with another TWAIN-compliant scanning program.

How to start

- ❑ Windows 8:
Select the Epson Scan icon on the desktop.
Or, select Epson Scan from the **Start** screen.
- ❑ Windows 7, Vista and XP:
Double-click the **EPSON Scan** icon on the desktop.
Or, select the start button icon or **Start > All Programs** or **Programs > EPSON > EPSON Scan > EPSON Scan**.
- ❑ Mac OS X:
Select **Applications > Epson Software > EPSON Scan**.

How to access the help

Click the **Help** button on the Epson Scan driver.

Starting Other Scanning Software

Note:

Some scanning software may not be included in some countries.

Epson Event Manager

This lets you assign any of the product buttons to open a scanning program. You can also save frequently used scanning settings, which can really speed up your scanning projects.

How to start

- ❑ Windows 8:
Right-click on the **Start** screen, or swipe from the bottom or top edge on the **Start** screen, and select **All apps > Epson Software > Event Manager**.
- ❑ Windows 7, Vista and XP:
Select the start button or **Start > All Programs** or **Programs > Epson Software > Event Manager**.
- ❑ Mac OS X:
Select **Applications > Epson Software**, and then double-click the **Launch Event Manager** icon.

How to access the help

- ❑ Windows:
Click the  icon in the upper right corner of the screen.
- ❑ Mac OS X:
Click **menu > Help > Epson Event Manager Help**.

Menu List of Control Panel

Menu List of Control Panel

You can use this product as a printer, copier, and scanner. When using one of these functions, except the printer function, select your desired function by selecting the corresponding Mode on the control panel. Each mode's main screen appears as you select the mode.

Note:

This function is available with XP-310 Series/XP-410 Series.

Copy Mode

XP-410 Series

Press ▼ to see the menu.

Menu	Setting item and description	
Print Settings	Density	-4 to +4
	Layout	With Border, Borderless* ¹
	Reduce/Enlarge	Actual Size, Auto Fit Page, 10×15cm->A4, A4->10×15cm, 13×18->10×15, 10×15->13×18, A5->A4, A4->A5, Custom Size
	Paper Size	A4, A5, 10×15cm(4×6in), 13×18cm(5×7in)
	Paper Type	Plain Paper, Photo Paper
	Quality	Draft* ² , Standard Quality, Best

XP-310 Series

Press ▼ to see the menu.

Menu	Setting item and description	
Settings	Layout	With Border, Borderless* ¹
	Reduce/Enlarge	Actual Size, Auto Fit, Custom
	Custom Size	Specify a percentage to reduce or enlarge your copy. Disabled when Auto Fit is selected.
	Paper Size	A4, 10×15cm(4×6in), 13×18cm(5×7in)
	Paper Type	Plain Paper, Photo Paper
	Quality	Draft, Standard Quality, Best
	Density	-4 to +4

*¹ Your image is slightly enlarged and cropped to fill the sheet of paper. Print quality may decline in the top and bottom areas of the printout, or the area may be smeared when printing.

*² For users in Belgium, draft mode is not available.

Menu List of Control Panel

Print Photo Mode

XP-410 Series

Press ▼ to see the menu.

Menu	Setting item and description	
Select Photos	Select by Date	
	Cancel Photo Selection	
Display Options	Select how to display photos on the LCD screen. Thumbnail shows a thumbnail view of your photos and allows you to select photos to print quickly. To select photos to print in thumbnail view, select a photo using the arrow keys and specify the number of copies using the +/- buttons. The number of copies is displayed on each of the selected thumbnail images.	
Print Settings	Paper Size* ¹	10x15cm(4x6in), 13x18cm(5x7in), A4
	Paper Type* ¹	Photo Paper, Plain Paper
	Borderless* ¹	With Border, Borderless* ²
	Quality* ¹	Standard Quality, Best
	Fix Red-Eye* ³	Off-Current, On-Current, Off-All, On-All
Crop/Zoom	You can crop (zoom in) a specified portion of a selected photo by moving a crop frame using the arrow buttons and +/- buttons.	
Select Group	If you have more than 999 images on your memory card, images are automatically divided into groups and the group selection screen is displayed. Select the group that contains the image you want to print. Images are sorted by the date they were taken. Use this menu to select another group.	

XP-310 Series

Press ▼ to see the menu.

Menu	Setting item and description	
Settings	Paper Size* ¹	10x15cm(4x6in), 13x18cm(5x7in), A4
	Paper Type* ¹	Photo Paper, Plain Paper
	Borderless* ¹	With Border, Borderless* ²
	Quality* ¹	Standard Quality, Best

*1 If you have selected multiple photos, these settings are applied to the all photos.

*2 Your image is slightly enlarged and cropped to fill the sheet of paper. Print quality may decline in the top and bottom areas of the printout, or the area may be smeared when printing.

*3 This setting does not change your original image. It only affects your printout. Depending on the type of photo, parts of the image other than the eyes may be corrected.

Menu List of Control Panel

Scan Mode

XP-410 Series

Menu	Setting item and description	
Scan to Memory Card	Format	JPEG, PDF
	Color	Color, B&W
	Scan Area ^{*1}	A4, Auto Cropping, Max Area
	Document	Text, Photograph
	Resolution	200dpi, 300dpi, 600dpi
	Contrast	-4 to +4
Scan to Cloud	For instructions on use, see the Epson Connect guide. The guide is available on the Epson Connect portal site. ➔ "Using Epson Connect Service" on page 8	
Scan to PC (JPEG)	➔ "Basic Scanning from the Control Panel" on page 55	
Scan to PC (PDF)		
Scan to PC (Email)		
Scan to PC (WSD)	This feature is only available for English versions of Windows 8/7/Vista.	

*1 If the edges of the photo are faint, try changing this setting.

XP-310 Series

Menu	Setting and Options
To PC (JPEG)	➔ "Basic Scanning from the Control Panel" on page 55
To PC (PDF)	
To PC (Email)	
To PC (WSD)	This feature is only available for English versions of Windows 8/7/Vista.

Menu List of Control Panel

More Functions Mode

XP-410 Series

Menu	Setting item and description	
Copy/Restore Photos	Color Restoration	Select On to automatically restore color of a faded photo.
	Display Options	Select how to display photos on the LCD screen.
	Print Settings	Select the paper size, quality, and whether or not to print with a border (margins).
	Crop/Zoom	You can crop (zoom in) a specified portion of a selected photo by moving a crop frame using the arrow buttons and +/- buttons.
Photo Layout Sheet	Print layout	2-up, 4-up, 8-up, 20-up, Upper 1/2, Lower 1/2, Photo ID
	Paper Size	10x15cm(4x6in), 13x18cm(5x7in), A4
	Paper Type	Photo Paper, Plain Paper
	Layout Method	Place photos manually allows you to lay out photos confirming a layout view.
	Select Photos	➔ "Print Photo Mode" on page 74
	Display Options	
	Print Settings	
	Crop/Zoom	
Slide Show	Images in a memory card are displayed on the LCD screen one by one. Press OK to print a displayed image.	

Menu List of Control Panel

Menu	Setting item and description	
Personal Stationery	Lined Papers	You can print lined paper, graph paper, or music paper.
	Writing Papers	You can print your original lined papers with or without a photo set as the background.
	Calendar	You can print monthly or weekly calendars. For monthly calendars, you can specify the year and month.
	Message Card	You can create your own message cards with or without a photo or a pre-designed image set as the decoration. ➔ "Printing message cards (XP-410 Series only)" on page 33
	Origami	You can create original envelopes with or without a pre-designed image set as the background or as the decoration. Two types of envelope are available. After printing, fold the paper following the instruction sheet that can be printed from the Origami Envelope Instruction menu. ➔ "Printing origami envelopes (XP-410 Series only)" on page 34

Personal Stationery Mode

XP-310 Series

Menu	Setting item and description	
Lined Papers	Lined Papers	You can print lined paper, graph paper, or music paper.
Writing Papers	Writing Papers	You can print your original lined papers with or without a photo set as the background.
Calendar	Calendar	You can print monthly or weekly calendars. For monthly calendars, you can specify the year and month.

Menu List of Control Panel

Wi-Fi Setup Mode

XP-410 Series

Menu	Setting item and description
Wi-Fi Setup Wizard	For details on the setting items, see the online Network Guide.
Push Button Setup (WPS)	
PIN Code Setup (WPS)	
Wi-Fi Direct Routerless Setup	
Wi-Fi Auto Connect	
Confirm Wi-Fi Settings	You can see the current network settings and print a network status sheet.
Disable Wi-Fi	Network problems may be resolved by disabling or initializing the Wi-Fi settings, and then making the settings again. For details, see the online Network Guide.

XP-310 Series

Menu	Setting item and description
Wi-Fi Setup Wizard	For details on the setting items, see the online Network Guide.
Push Button (WPS)	
PIN Code (WPS)	
Wi-Fi Direct Setup	
Wi-Fi Auto Connect	
Print Status Sheet	You can see the current network settings and print a network status sheet.
Disable Wi-Fi	Network problems may be resolved by disabling or initializing the Wi-Fi settings, and then making the settings again. For details, see the online Network Guide.

Setup Mode

Menu	Setting item and description	
Ink Levels	Checks the status of ink cartridges.	
Maintenance	Nozzle Check	Prints a nozzle check pattern to check the condition of the print head.
	Head Cleaning	Cleans the print head to improve the condition of the print head.
	Head Alignment	Adjusts the alignment of the print head.
	Ink Cartridge Replacement	Select to replace ink cartridges.

Menu List of Control Panel

Menu	Setting item and description	
Printer Setup	Sound* ¹	Select Off to turn off beep sound of buttons.
	Power Off Timer	➔ "Saving Power" on page 102
	Sleep Timer	
	Language	You can change the language displayed on the LCD panel.
Wi-Fi Settings	Wi-Fi Setup	See the online Network Guide. You can access the Wi-Fi Setup menus directly by selecting Wi-Fi Setup from the Home menu.
	Manual Wi-Fi Setup* ¹	
	Wi-Fi Connection Check	You can check the network connection status, and print the report. If there is any problem with the connection, the report helps you find the solution.
	Confirm Wi-Fi Settings* ²	You can see the current network settings and print a network status sheet.
Epson Connect Services* ¹	Status	You can check whether your printer is registered or connected to Epson Connect service. For instructions on use, see the Epson Connect guide. The guide is available on the Epson Connect portal site. ➔ "Using Epson Connect Service" on page 8
	Email Address	You can see your e-mail address registered in Epson Connect.
	Suspend/Resume	Suspend/resume all Epson Connect services.
	Restore Default Settings	Delete your registered printer and initializes Epson Connect settings to the factory default settings.
Google Cloud Print Services* ¹	Status	You can check whether your printer is registered or connected to Google Cloud Print service. For instructions on use, see the Epson Connect guide. The guide is available on the Epson Connect portal site. ➔ "Using Epson Connect Service" on page 8
	Suspend/Resume	Suspend/resume all Google Cloud Print services.
	Restore Default Settings	Delete your registered printer and initializes Google Cloud Print settings to the factory default settings.
File Sharing Setup	USB, Wi-Fi	Select which type of computer you want to give write access to the memory card. You can select a USB-connected or a Wi-Fi-connected computer.
Restore Default Settings	Wi-Fi Settings	Initializes Wi-Fi settings to the factory default settings.
	All except Wi-Fi Settings	Initializes all settings except for Wi-Fi settings to the factory default settings.
	All Settings	Initializes all settings to the factory default settings.

*1 XP-310 Series does not have these functions.

*2 The menu name for XP-310 Series is "Print Status Sheet".

Replacing Ink Cartridges

Ink Cartridge Safety Instructions, Precautions, and Specifications

Safety instructions

Observe the following when handling the ink cartridges:

- Keep ink cartridges out of the reach of children.
- Be careful when you handle used ink cartridges, as there may be some ink around the ink supply port. If ink gets on your skin, wash the area thoroughly with soap and water. If ink gets into your eyes, flush them immediately with water. If discomfort or vision problems continue after a thorough flushing, see a doctor immediately. If ink gets into your mouth, spit it out immediately and see a doctor right away.
- Do not remove or tear the label on the cartridge; this can cause leakage.

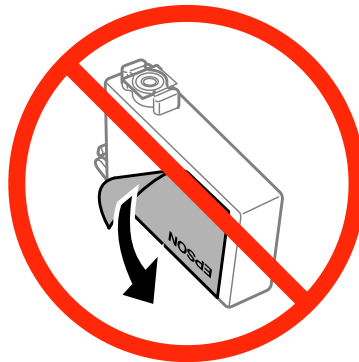

- Do not remove the transparent seal from the bottom of the cartridge; otherwise, the cartridge may become unusable.



- Do not disassemble or remodel the ink cartridge, otherwise you may not be able to print normally.

Replacing Ink Cartridges

- ❑ Do not touch the green IC chip or the small window on the side of the cartridge. Doing so may prevent normal operation and printing.

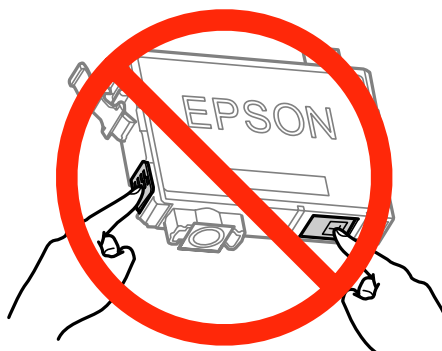

- ❑ Do not leave the product with the ink cartridges removed or do not turn off the product during cartridge replacement. Otherwise, ink remaining in the print head nozzles will dry out and you may not be able to print.

Precautions on ink cartridge replacement

Read all of the instructions in this section before replacing the ink cartridges.

- ❑ Epson recommends the use of genuine Epson ink cartridges. Epson cannot guarantee the quality or reliability of non-genuine ink. The use of non-genuine ink may cause damage that is not covered by Epson's warranties, and under certain circumstances, may cause erratic product behavior. Information about non-genuine ink levels may not be displayed.
- ❑ Gently shake only the black ink cartridge four or five times before opening the package. Do not shake the other color cartridges.
- ❑ Do not shake ink cartridges too vigorously; otherwise ink may leak from the cartridge.
- ❑ This product uses ink cartridges equipped with an IC chip that monitors information such as the amount of remaining ink for each cartridge. This means that even if the cartridge is removed from the product before it is expended, you can still use the cartridge after reinserting it back into the product. However, when reinserting a cartridge, some ink may be consumed to guarantee product performance.
- ❑ You cannot use the cartridge that came with your product for the replacement.
- ❑ To maintain optimum print head performance, some ink is consumed from all cartridges not only during printing but also during maintenance operations such as ink cartridge replacement and print head cleaning.
- ❑ If you need to remove an ink cartridge temporarily, be sure to protect the ink supply area from dirt and dust. Store the ink cartridge in the same environment as the product. When storing the cartridge, be sure that its label identifying the color of the ink cartridge is facing upward. Do not store ink cartridges upside down.
- ❑ The ink supply port is equipped with a valve designed to contain the release of excess ink; there is no need to supply your own covers or plugs. However, careful handling is recommended. Do not touch the supply port of the ink cartridge or its surrounding area.
- ❑ For maximum ink efficiency, only remove an ink cartridge when you are ready to replace it. Ink cartridges with low ink status may not be used when reinserted.

Replacing Ink Cartridges

- ❑ Do not open the ink cartridge package until you are ready to install it in the product. The cartridge is vacuum packed to maintain its reliability. If you leave a cartridge unpacked for a long time before using it, normal printing may not be possible.
- ❑ Install all ink cartridges; otherwise, you cannot print.
- ❑ When color ink is expended and black ink still remains, you can continue printing temporarily with black ink only. For more information refer to [“Temporarily Printing with Black Ink When Color Ink Cartridges are Expended” on page 85](#).
- ❑ If an ink cartridge is running low, prepare a new ink cartridge.
- ❑ Be careful not to break the hooks on the side of the ink cartridge when you remove it from the package.
- ❑ You must remove the yellow tape from the cartridge before installing it; otherwise, print quality may decline or you may not be able to print.
- ❑ After bringing an ink cartridge inside from a cold storage site, allow it to warm up at room temperature for at least three hours before using it.
- ❑ Store ink cartridges in a cool, dark place.
- ❑ Store ink cartridges with their labels facing upward. Do not store cartridges upside down.

Ink Cartridge Specifications

- ❑ Epson recommends using the ink cartridge before the date printed on the package.
- ❑ The ink cartridges packaged with your product are partly used during initial setup. In order to produce high quality printouts, the print head in your product will be fully charged with ink. This one-off process consumes a quantity of ink and therefore these cartridges may print fewer pages compared to subsequent ink cartridges.
- ❑ Quoted yields may vary depending on the images that you are printing, the paper type that you are using, the frequency of your prints and environmental conditions such as temperature.
- ❑ To ensure you receive premium print quality and to help protect your print head, a variable ink safety reserve remains in the cartridge when your product indicates to replace the cartridge. The yields quoted for you do not include this reserve.
- ❑ Although the ink cartridges may contain recycled materials, this does not affect product function or performance.
- ❑ When printing in monochrome or grayscale, color inks instead of black ink may be used depending on the paper type or print quality settings. This is because a mixture of color inks is used to create black.

Checking the Ink Cartridge Status

For Windows

Note:

- ❑ The order in which ink cartridges are listed varies depending on the product.
- ❑ When an ink cartridge is running low, the Low Ink Reminder screen automatically appears. You can also check the ink cartridge status from this screen. If you do not want to display this screen, first access the printer driver and then click the **Maintenance** tab, **Extended Settings** button, and then **Monitoring Preferences** button. On the Monitoring Preferences screen, clear the **See Low Ink Reminder alerts** check box.

To check the ink cartridge status, do one of the following:

- ❑ Double-click the product shortcut icon on your Windows taskbar. To add a shortcut icon to the taskbar, see the following section:
 - ➔ [“From the shortcut icon on the taskbar” on page 37](#)
- ❑ Open the printer driver, click the **Maintenance** tab, then click the **EPSON Status Monitor 3** button. A graphic displays the ink cartridge status.

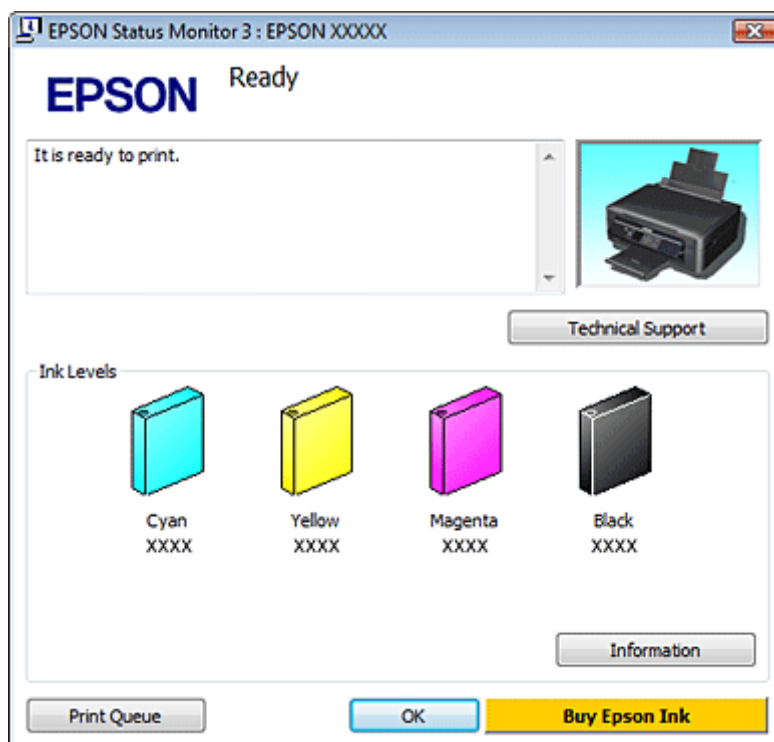

Note:

- ❑ If EPSON Status Monitor 3 does not appear, access the printer driver and click the **Maintenance** tab and then the **Extended Settings** button. In the Extended Settings window, check the **Enable EPSON Status Monitor 3** check box.
- ❑ The ink levels displayed are an approximate indication.

Replacing Ink Cartridges

For Mac OS X

You can check the ink cartridge status using EPSON Status Monitor. Follow the steps below.

- 1 Access the Epson Printer Utility 4.
➔ [“Accessing the printer driver for Mac OS X” on page 37](#)
- 2 Click the **EPSON Status Monitor** icon. The EPSON Status Monitor appears.

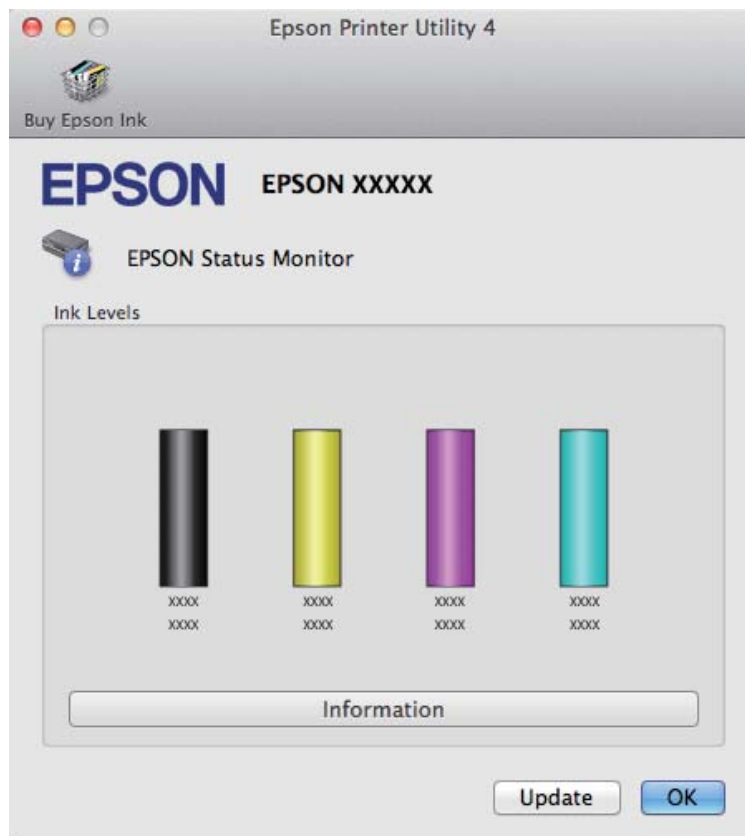

Note:

- The graphic displays the ink cartridge status when EPSON Status Monitor was first opened. To update the ink cartridge status, click **Update**.
- The order in which ink cartridges are listed varies depending on the product.
- The ink levels displayed are an approximate indication.

Using the control panel

Note:

This function is available with XP-310 Series/XP-410 Series.

- 1 Enter **Setup** mode from the Home menu.

Replacing Ink Cartridges

2 Select Ink Levels.

Note:

The ink levels displayed are an approximate indication.

Temporarily Printing with Black Ink When Color Ink Cartridges are Expended

When color ink is expended and black ink still remains, you can continue printing for a short time using only black ink. However, you should replace the expended ink cartridge(s) as soon as possible. See the following section to continue printing temporarily with black ink.

Note:

- This feature is not available when photos and documents are printed or copied directly from the printer without using a computer.*
- The actual amount of time will vary depending on the usage conditions, images printed, print settings, and frequency of use.*

For Windows

Follow the steps below to continue printing temporarily with black ink.

Replacing Ink Cartridges

- 1 When EPSON Status Monitor 3 tells you to cancel your print job, click **Cancel** or **Cancel Print** to cancel your print job.

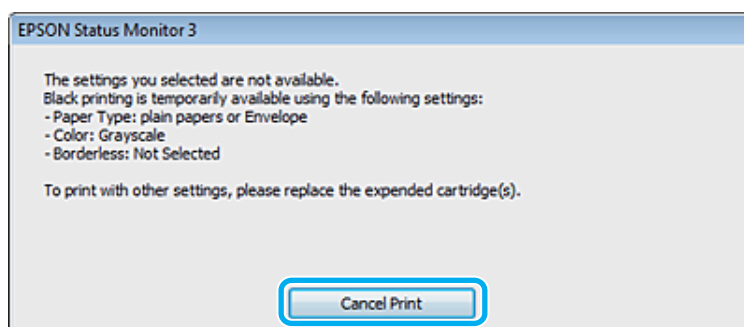
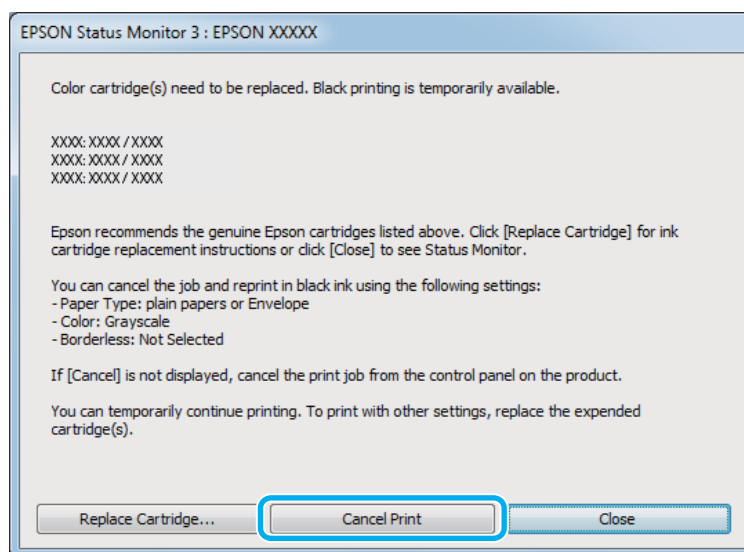

Note:

If the error stating that a color ink cartridge is expended originates with another computer on the network, you may need to cancel the print job at the product. If the product is not equipped with an LCD screen, press the Ⓞ button on the product for three seconds to cancel the print job.

- 2 Load plain paper or envelope.
- 3 Access the printer settings.
➔ “Accessing the printer driver for Windows” on page 36
- 4 Click the Main tab, and make suitable settings.
- 5 Select **plain papers** or **Envelope** as the Type setting.
- 6 Select the **Grayscale** check box in **Print Options**.
- 7 Click **OK** to close the printer settings window.

Replacing Ink Cartridges

- 8 Print your file.
- 9 EPSON Status Monitor 3 is displayed on your computer screen again. Click **Print in Black** to print with black ink.

For Mac OS X

Follow the steps below to continue printing temporarily with black ink.

- 1 If printing can not be resumed, click the product icon in the Dock. If an error message is displayed prompting you to cancel the print job, click **Delete** and follow the steps below to reprint the document with black ink.

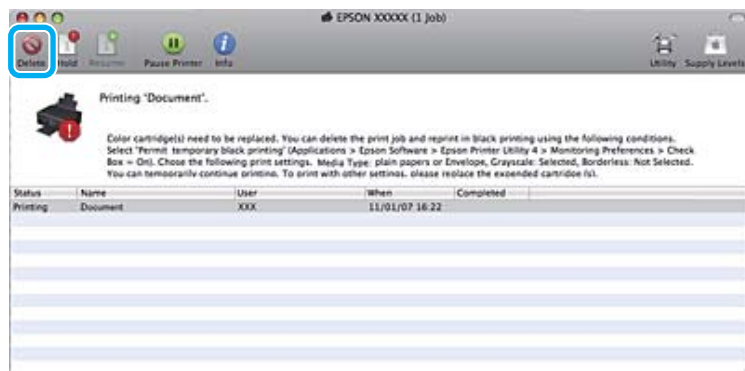

Note:

If the error stating that a color ink cartridge is expended originates with another computer on the network, you may need to cancel the print job at the product. If the product is not equipped with an LCD screen, press the  button on the product for three seconds to cancel the print job.

For Mac OS X 10.8:

Click the  button, and if an error message appears, click **OK**. Follow the steps bellow to reprint the document with black ink.

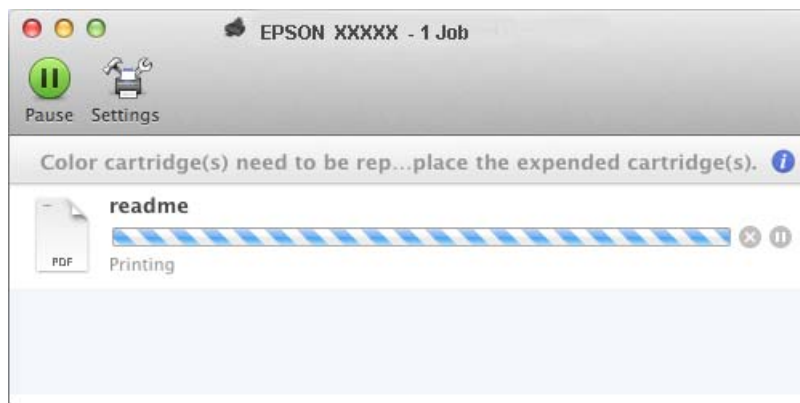

- 2 Open **System Preferences**, click **Print & Scan** (Mac OS X 10.8 or 10.7) or **Print & Fax** (Mac OS X 10.6 or 10.5), and select the product from the Printers list. Next, click **Options & Supplies** and then **Driver**.
- 3 Select **On** for Permit temporary black printing.

Replacing Ink Cartridges

- 4 Load plain paper or envelope.
- 5 Access the Print dialog box.
➔ [“Accessing the printer driver for Mac OS X” on page 37](#)
- 6 Click the **Show Details** button (for Mac OS X 10.8 or 10.7) or the ▼ button (for Mac OS X 10.6 or 10.5) to extend this dialog box.
- 7 Select the product you are using as the Printer setting, and then make suitable settings.
- 8 Select **Print Settings** from the pop-up menu.
- 9 Select **plain papers** or **Envelope** as the Media Type setting.
- 10 Select the **Grayscale** check box.
- 11 Click **Print** to close the Print dialog box.

Conserving Black Ink When the Cartridge Is Low (For Windows Only)

The window below appears when black ink runs low and there is more color ink than black ink. It appears only when **plain papers** is selected as the paper type, and **Normal** is selected as the Paper & Quality Options in the Advanced tab.

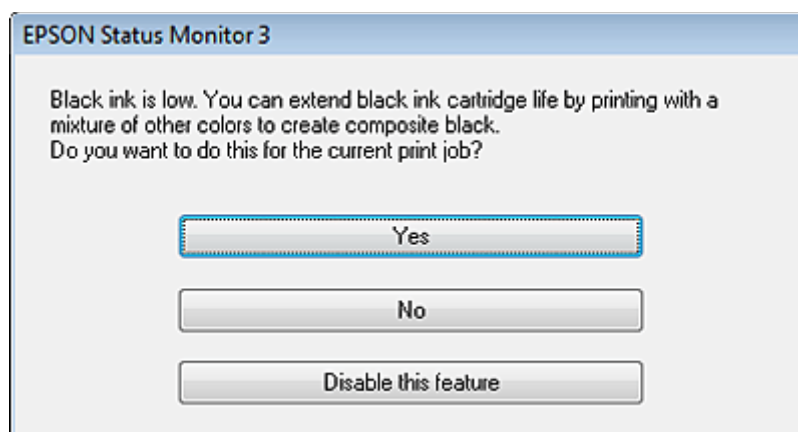

The window gives you the option to either continue using black ink normally or conserve black ink by using a mixture of color inks to create black.

- Click the **Yes** button to use a mixture of color inks to create black. You will see the same window the next time you print a similar job.

Replacing Ink Cartridges

- ❑ Click the **No** button to continue using the remaining black ink for the job you are printing. You will see the same window the next time you print a similar job, and again have the option to conserve black ink.
- ❑ Click **Disable this feature** to continue using the remaining black ink.

Replacing an Ink Cartridge

Using the control panel (XP-310 Series/XP-410 Series)

- 1 When prompted to replace an ink cartridge, open the scanner unit and press **OK**. The ink cartridge holder moves to the ink cartridge replacement position. When you replace an ink cartridge before it is expended, select the following menu. **Setup > Maintenance > Ink Cartridge Replacement.**

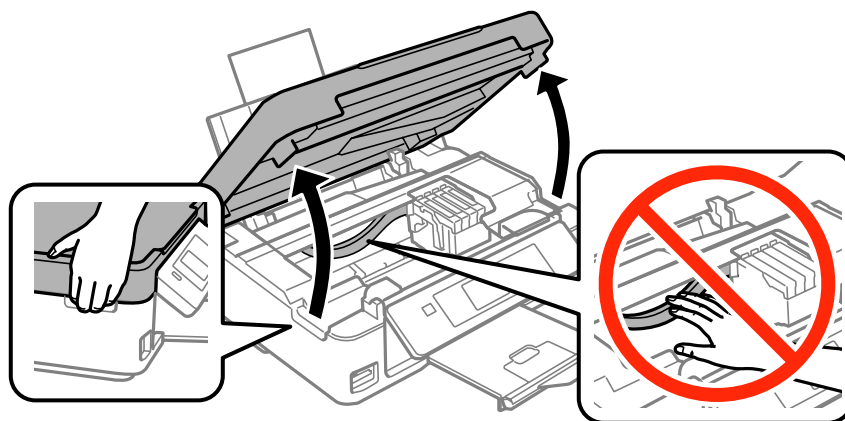

! **Important:**
Do not move the ink cartridge holder by hand; otherwise, you may damage the product.

- 2 Pinch and remove the ink cartridge.

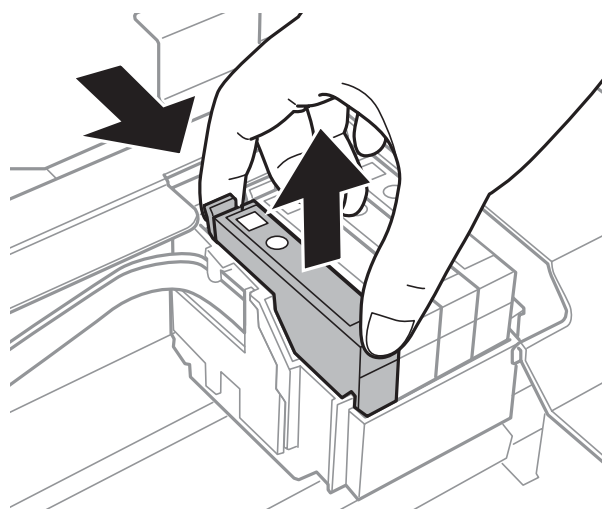

Replacing Ink Cartridges

Note:

Removed ink cartridges may have ink around the ink supply port, so be careful not to get any ink on the surrounding area when removing the cartridges.

3

If you replace the black ink cartridge, gently shake the new black ink cartridge four or five times and then unpack. When replacing the other color cartridges, do not shake the cartridges. Just unpack them.

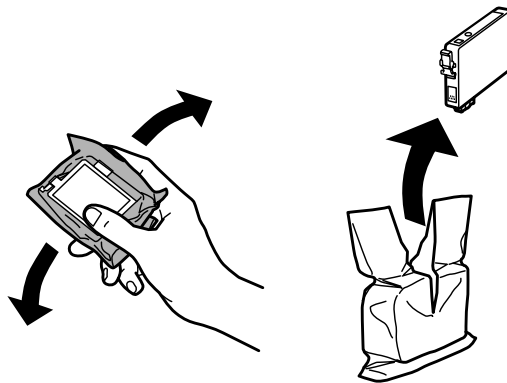

Important:

- ❑ Be careful not to break the hooks on the side of the ink cartridge when you remove it from the package.
- ❑ Do not touch the green IC chip or the small window on the side of the cartridge. Doing so may prevent normal operation and printing.

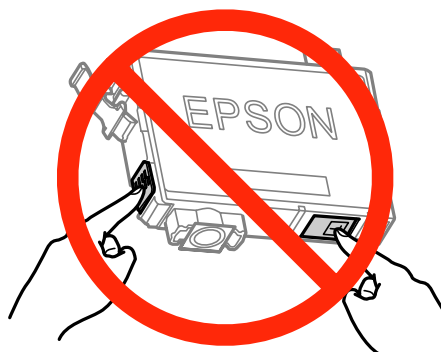

4

Remove only the yellow tape.

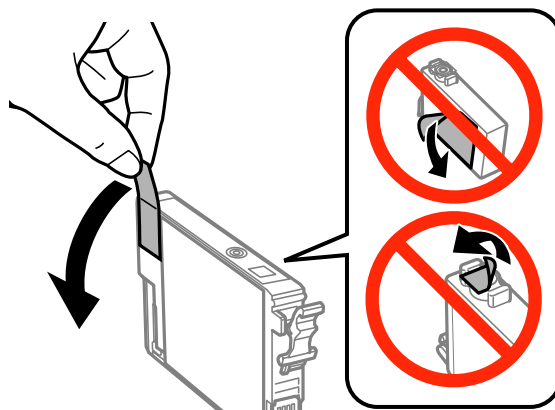

Replacing Ink Cartridges

! Important:

- ❑ You must remove the yellow tape from the cartridge before installing it; otherwise, print quality may decline or you may not be able to print.
- ❑ If you have installed an ink cartridge without removing the yellow tape, take the cartridge out of the product, remove the yellow tape, and then reinstall it.
- ❑ Do not remove the transparent seal from the bottom of the cartridge; otherwise, the cartridge may become unusable.
- ❑ Do not remove or tear the label on the cartridge; otherwise, ink will leak.

5

Insert the cartridge and press it until it clicks. Make sure the top surface of the ink cartridges align.

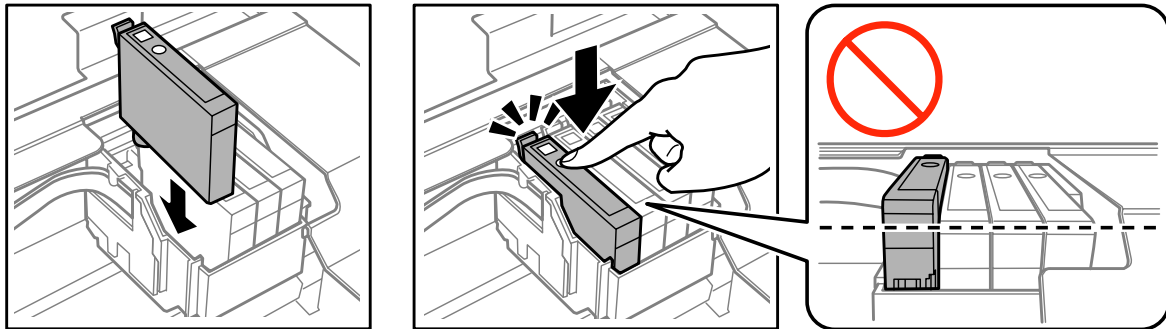

6

Close the scanner unit slowly and press the \diamond button. Ink charging starts.

Note:

- ❑ The \odot light continues to flash while the product is charging ink. Do not turn off the product during ink charging. If the ink charging is incomplete, you may not be able to print.
- ❑ If you had to replace an ink cartridge during copying, to ensure copy quality after ink charging is finished, cancel the job that is copying and start again from placing the originals.

Ink cartridge replacement is complete. The product will return to its previous status.

Replacing Ink Cartridges

Using the control panel (XP-210 Series)

- 1 Open the scanner unit.

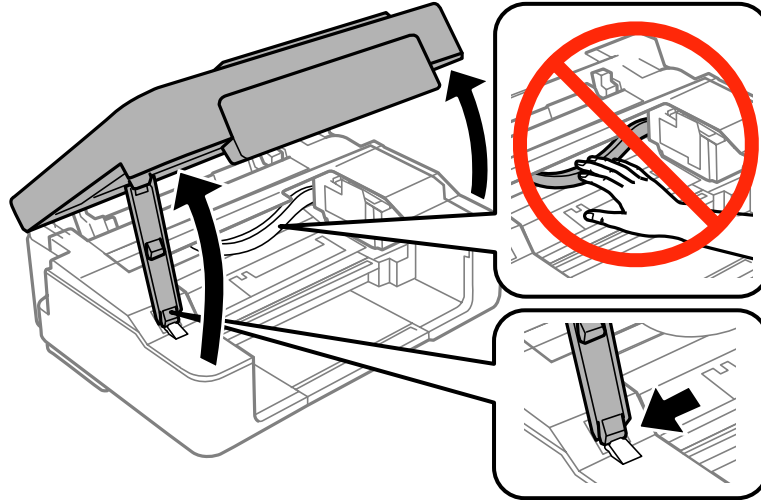

- 2 If the ● light is on, press the Ⓞ button.
If the ● light is flashing or off, press the Ⓞ button for six seconds until the ink cartridge holder moves.

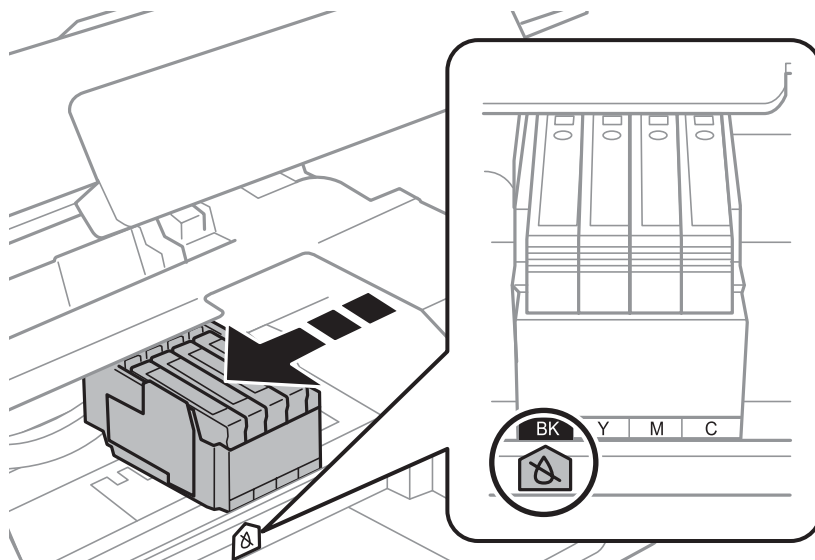

The ink cartridge holder moves to the ink cartridge check position. The cartridge indicated by the ⚠ icon is expended or low.



Important:

Do not move the ink cartridge holder by hand; otherwise, you may damage the product. Always press the Ⓞ button to move it.

Replacing Ink Cartridges

- 3 Press the  button again.
If more than one ink cartridge is expended, the ink cartridge holder moves to the  mark. This occurs each time you press the  button until all expended ink cartridges have been indicated.

Once all of the expended ink cartridges have been indicated, the ink cartridge holder moves to the ink cartridge replacement position when you press the  button.

- 4 Pinch and remove the ink cartridge.

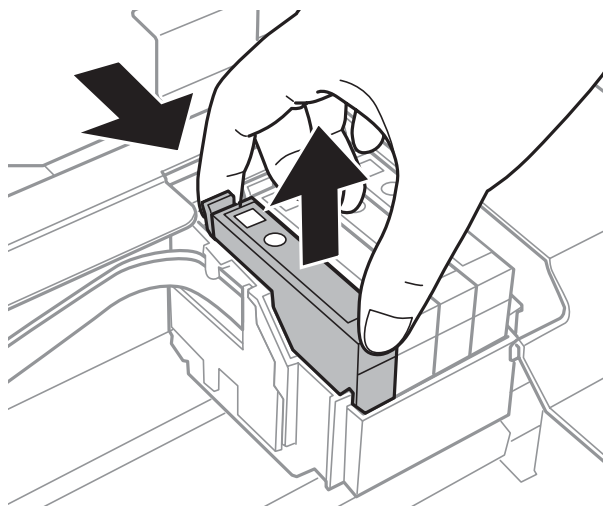

Note:
Removed ink cartridges may have ink around the ink supply port, so be careful not to get any ink on the surrounding area when removing the cartridges.

- 5 If you replace the black ink cartridge, gently shake the new black ink cartridge four or five times and then unpack. When replacing the other color cartridges, do not shake the cartridges. Just unpack them.

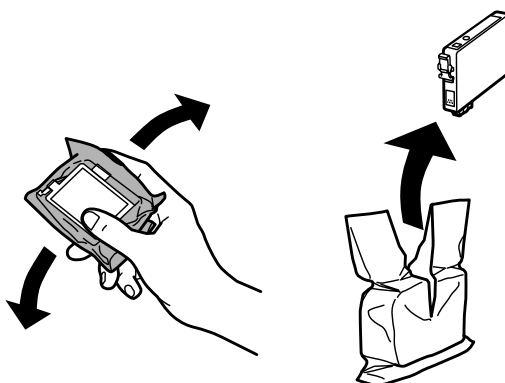

Replacing Ink Cartridges

! Important:

- ❑ Be careful not to break the hooks on the side of the ink cartridge when you remove it from the package.
- ❑ Do not touch the green IC chip or the small window on the side of the cartridge. Doing so may prevent normal operation and printing.

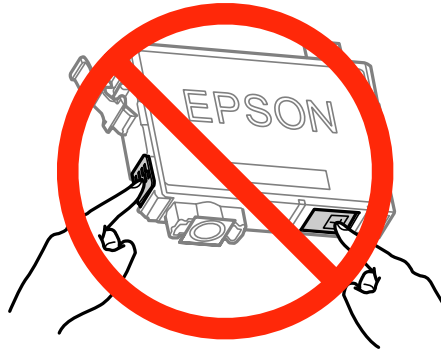

6

Remove only the yellow tape.

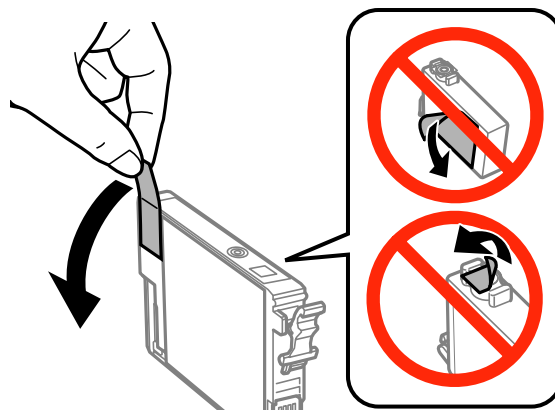



! Important:

- ❑ You must remove the yellow tape from the cartridge before installing it; otherwise, print quality may decline or you may not be able to print.
- ❑ If you have installed an ink cartridge without removing the yellow tape, take the cartridge out of the product, remove the yellow tape, and then reinstall it.
- ❑ Do not remove the transparent seal from the bottom of the cartridge; otherwise, the cartridge may become unusable.
- ❑ Do not remove or tear the label on the cartridge; otherwise, ink will leak.

Replacing Ink Cartridges

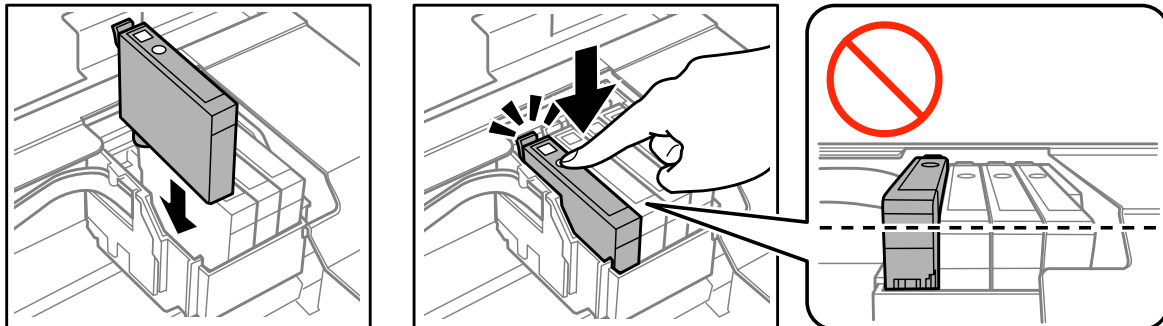
- 7** Insert the cartridge and press it until it clicks. Make sure the top surface of the ink cartridges align.



- 8** Close the scanner unit and press . Ink charging starts. This process takes about two minutes to complete.

Note:

- The  light continues to flash while the product is charging ink. Do not turn off the product during ink charging. If the ink charging is incomplete, you may not be able to print.
- If you had to replace an ink cartridge during copying, to ensure copy quality after ink charging is finished, cancel the job that is copying and start again from placing the originals.

Ink cartridge replacement is complete. The product will return to its previous status.

For Windows

When you need to replace an expended ink cartridge, click **How to** in the status monitor window. Follow the on-screen instructions to replace the cartridge.

For more information on using your computer to replace ink cartridges, see the section below.

➔ [“For Windows” on page 119.](#)

Replacing Ink Cartridges

If you need to replace an ink cartridge before it is low or expended, click the button on the **Maintenance** tab in your printer driver.

➔ [“Accessing the printer driver for Windows” on page 36](#)

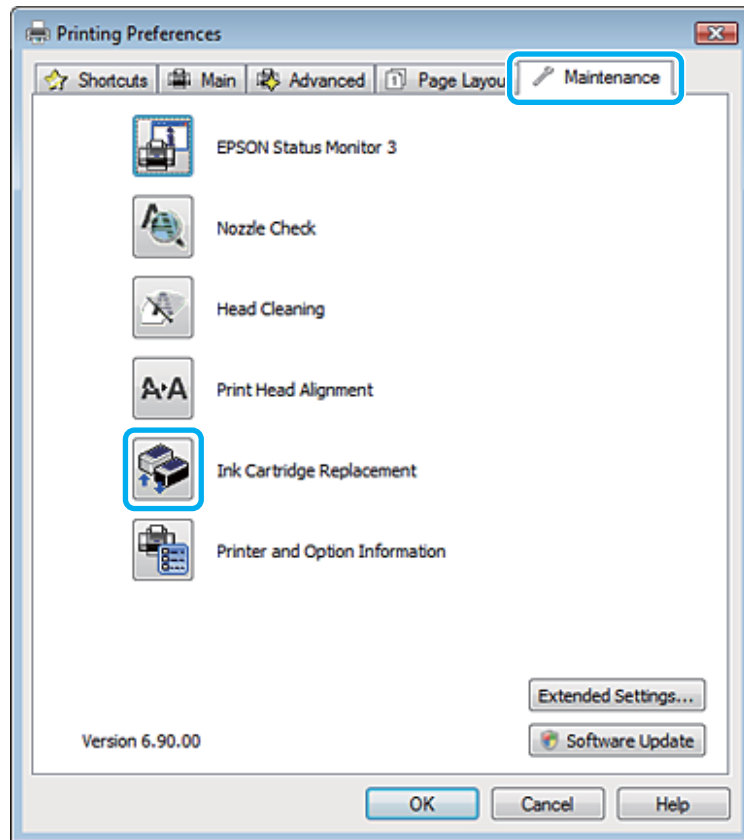

For more information on using the printer utilities, see the online help.

For Mac OS X

When you need to replace an expended ink cartridge, click **How to** in the status monitor window. Follow the on-screen instructions to replace the cartridge.

For more information on using your computer to replace ink cartridges, see the section below.

➔ [“For Mac OS X” on page 120.](#)

If you need to replace an ink cartridge before it is low or expended, access the Epson Printer Utility 4. Then click the Ink Cartridge Replacement icon.

➔ [“Accessing the printer driver for Mac OS X” on page 37.](#)

Maintaining Your Product and Software

Checking the Print Head Nozzles

If you find that the printout is unexpectedly faint or that dots are missing, you may be able to identify the problem by checking the print head nozzles.

You can check the print head nozzles from your computer by using the Nozzle Check utility or from the product by using the buttons.

Using the Nozzle Check utility for Windows

Follow the steps below to use the Nozzle Check utility.

- 1 Make sure that no warnings or errors are indicated in the control panel.
- 2 Make sure that A4-size paper is loaded in the sheet feeder.
- 3 Right-click the product icon on the taskbar, then select **Nozzle Check**.
If the product icon does not appear, refer to the following section to add the icon.
➔ [“From the shortcut icon on the taskbar” on page 37](#)
- 4 Follow the on-screen instructions.

Using the Nozzle Check utility for Mac OS X

Follow the steps below to use the Nozzle Check utility.

- 1 Make sure that no warnings or errors are indicated in the control panel.
- 2 Make sure that A4-size paper is loaded in the sheet feeder.
- 3 Access the Epson Printer Utility 4.
➔ [“Accessing the printer driver for Mac OS X” on page 37](#)
- 4 Click the **Nozzle Check** icon.
- 5 Follow the on-screen instructions.

Using the control panel (XP-310 Series/XP-410 Series)

Follow the steps below to check the print head nozzles using the product control panel.

- 1 Make sure that no warnings or errors are indicated in the control panel.
- 2 Make sure that A4-size paper is loaded in the sheet feeder.
- 3 Enter **Setup** mode from the Home menu.
- 4 Select **Maintenance**.
- 5 Select **Nozzle Check** and follow the instructions in the LCD screen to print a nozzle check pattern.

Below are two sample nozzle check patterns.

Compare the quality of the printed check page with the sample shown below. If there are no print quality problems, such as gaps or missing segments in the test lines, the print head is fine.





If any segment of the printed lines is missing, as shown below, this could mean a clogged ink nozzle or a misaligned print head.



- ➔ [“Cleaning the Print Head” on page 99](#)
- ➔ [“Aligning the Print Head” on page 101](#)

Using the control panel (XP-210 Series)

Follow the steps below to check the print head nozzles using the product buttons.

- 1 Make sure that no warnings or errors are indicated in the control panel.
- 2 Turn off the product.
- 3 Make sure that A4-size paper is loaded in the sheet feeder.
- 4 Holding down the  button and press the  button to turn on the product.

Maintaining Your Product and Software

5 When the product turns on, release both the buttons. The product prints the nozzle check pattern.

Below are two sample nozzle check patterns.

Compare the quality of the printed check page with the sample shown below. If there are no print quality problems, such as gaps or missing segments in the test lines, the print head is fine.



If any segment of the printed lines is missing, as shown below, this could mean a clogged ink nozzle or a misaligned print head.



➔ [“Cleaning the Print Head” on page 99](#)

➔ [“Aligning the Print Head” on page 101](#)

Cleaning the Print Head

If you find that the printout is unexpectedly faint or that dots are missing, you may be able to solve these problems by cleaning the print head, which ensures that the nozzles are delivering ink properly.

You can clean the print head from your computer using the Head Cleaning utility in the printer driver or from the product by using the buttons.



Important:

Do not open the scanner unit or turn off the product during head cleaning. If the head cleaning is incomplete, you may not be able to print.

Note:

- Because print head cleaning uses some ink from all cartridges, clean the print head only if quality declines; for example, if the printout is blurry or the color is incorrect or missing.
- Use the Nozzle Check utility first to confirm that the print head needs to be cleaned. This saves ink.
- When ink is low you may not be able to clean the print head. When ink is expended you cannot clean the print head. Replace the appropriate ink cartridge first.
- If print quality has not improved after repeating this procedure about four times, turn the product off and wait for at least six hours. Then run the nozzle check again and repeat the head cleaning if necessary. If print quality has still not improved, contact Epson support.
- To maintain print quality, we recommend printing a few pages on a regular basis.

Using the Head Cleaning utility for Windows

Follow the steps below to clean the print head using the Head Cleaning utility.

- 1 Make sure that no warnings or errors are indicated in the control panel.
- 2 Right-click the product icon on the taskbar, then select **Head Cleaning**.
If the product icon does not appear, refer to the following section to add the icon.
➔ [“From the shortcut icon on the taskbar” on page 37](#)
- 3 Follow the on-screen instructions.

Using the Head Cleaning utility for Mac OS X

Follow the steps below to clean the print head using the Head Cleaning utility.

- 1 Make sure that no warnings or errors are indicated in the control panel.
- 2 Access the Epson Printer Utility 4.
➔ [“Accessing the printer driver for Mac OS X” on page 37](#)
- 3 Click the **Head Cleaning** icon.
- 4 Follow the on-screen instructions.

Using the control panel (XP-310 Series/XP-410 Series)

Follow the steps below to clean the print head using the product control panel.

- 1 Make sure that no warnings or errors are indicated in the control panel.
- 2 Enter **Setup** mode from the Home menu.
- 3 Select **Maintenance**.
- 4 Select **Head Cleaning**.
- 5 Follow the instructions on the LCD screen to continue.

Using the control panel (XP-210 Series)

Follow the steps below to clean the print head using the product buttons.

- 1 Make sure that no warnings or errors are indicated in the control panel.
- 2 Hold down the ⏻ button for three seconds.
The product starts cleaning the print head and the ⏻ light begins flashing.
- 3 When the ⏻ light stops flashing, print a nozzle check pattern to confirm that the head is clean.
➔ [“Checking the Print Head Nozzles” on page 97](#)

Aligning the Print Head

If you notice a misalignment of vertical lines or horizontal banding, you may be able to solve this problem by using the Print Head Alignment utility in your printer driver or by using the product buttons.

Refer to the appropriate section below.

Note:

Do not press ⏻ to cancel printing while printing a test pattern with the Print Head Alignment utility.

Using the Print Head Alignment utility for Windows

Follow the steps below to align the print head using the Print Head Alignment utility.

- 1 Make sure that no warnings or errors are indicated in the control panel.
- 2 Make sure A4-size paper is loaded in the sheet feeder.
- 3 Right-click the product icon on the taskbar, then select **Print Head Alignment**.
If the product icon does not appear, refer to the following section to add the icon.
➔ [“From the shortcut icon on the taskbar” on page 37](#)
- 4 Follow the on-screen instructions to align the print head.

Using the Print Head Alignment utility for Mac OS X

Follow the steps below to align the print head using the Print Head Alignment utility.

- 1 Make sure that no warnings or errors are indicated in the control panel.

Maintaining Your Product and Software

- 2 Make sure A4-size paper is loaded in the sheet feeder.
- 3 Access the Epson Printer Utility 4.
➔ [“Accessing the printer driver for Mac OS X” on page 37](#)
- 4 Click the **Print Head Alignment** icon.
- 5 Follow the on-screen instructions to align the print head.

Using the control panel (XP-310 Series/XP-410 Series)

Follow the steps below to align the print head using the product control panel.

- 1 Make sure that no warnings or errors are indicated in the control panel.
- 2 Make sure that A4-size paper is loaded in the sheet feeder.
- 3 Enter **Setup** mode from the Home menu.
- 4 Select **Maintenance**.
- 5 Select **Head Alignment** and follow the instructions in the LCD screen to print the patterns.
- 6 Find the most solid pattern in each of #1 to #4 groups.

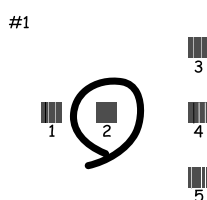

- 7 Enter the pattern number for the most solid pattern in #1 group.
- 8 Repeat step 7 for the other groups (#2 to #4).
- 9 Finish aligning the print head.

Saving Power

The product enters sleep mode or turns off automatically if no operations are performed for a set period.

Maintaining Your Product and Software

You can adjust the time before power management is applied. Any increase will affect the product's energy efficiency. Please consider the environment before making any change.

Follow the steps below to adjust the time.

For Windows

- 1 Access the printer settings.
➔ [“Accessing the printer driver for Windows” on page 36](#)
- 2 Click the **Maintenance** tab, and then click the **Printer and Option Information** button.
- 3 Select **Off**, **30 minutes**, **1 hour**, **2 hours**, **4 hours**, **8 hours**, or **12 hours** as the Power Off Timer setting, and click the **Send** button.
- 4 Select **3 minutes**, **5 minutes**, **10 minutes**, or **15 minutes** as the Sleep Timer setting, and click the **Send** button.
- 5 Click the **OK** button.

For Mac OS X

- 1 Access the Epson Printer Utility 4.
➔ [“Accessing the printer driver for Mac OS X” on page 37](#)
- 2 Click the **Printer Settings** button. The Printer Settings screen appears.
- 3 Select **Off**, **30 minutes**, **1 hour**, **2 hours**, **4 hours**, **8 hours**, or **12 hours** as the Power Off Timer setting.
- 4 Select **3 minutes**, **5 minutes**, **10 minutes**, or **15 minutes** as the Sleep Timer setting.
- 5 Click the **Apply** button.

Using the control panel (XP-310 Series/XP-410 Series)

- 1 Enter **Setup** mode from the Home menu.
- 2 Select **Printer Setup**.
- 3 Select **Power Off Timer**.
- 4 Select **Off**, **30minutes**, **1h**, **2h**, **4h**, **8h**, or **12h**.

Maintaining Your Product and Software

5 Select **Sleep Timer**.

6 Select **3minutes**, **5minutes**, **10minutes**, or **15 minutes**.

Making Network Service Settings

Note:

XP-212/XP-213/XP-216 do not support this function.

You can make network service settings such as Epson Connect, AirPrint, or Google Cloud Print using a Web browser on your computer, smartphone, tablet PC, or laptop that is connected to the same network as the product.

Enter the product's IP address in the address bar of the Web browser and search for the product.

<Example>

IPv4: `http://192.168.11.46`

IPv6: `http://[fe80::226:abff:feff:37cd]/`

Note:

You can check your product's IP address on the product's control panel or by printing a network status sheet.

For products with an LCD screen: ➔ ["Setup Mode" on page 78](#)

For products without an LCD screen: Press  to print the network status sheet.

Maintaining Your Product and Software

When the product is found successfully, the product's web page is displayed as shown below. Select the menu you want.

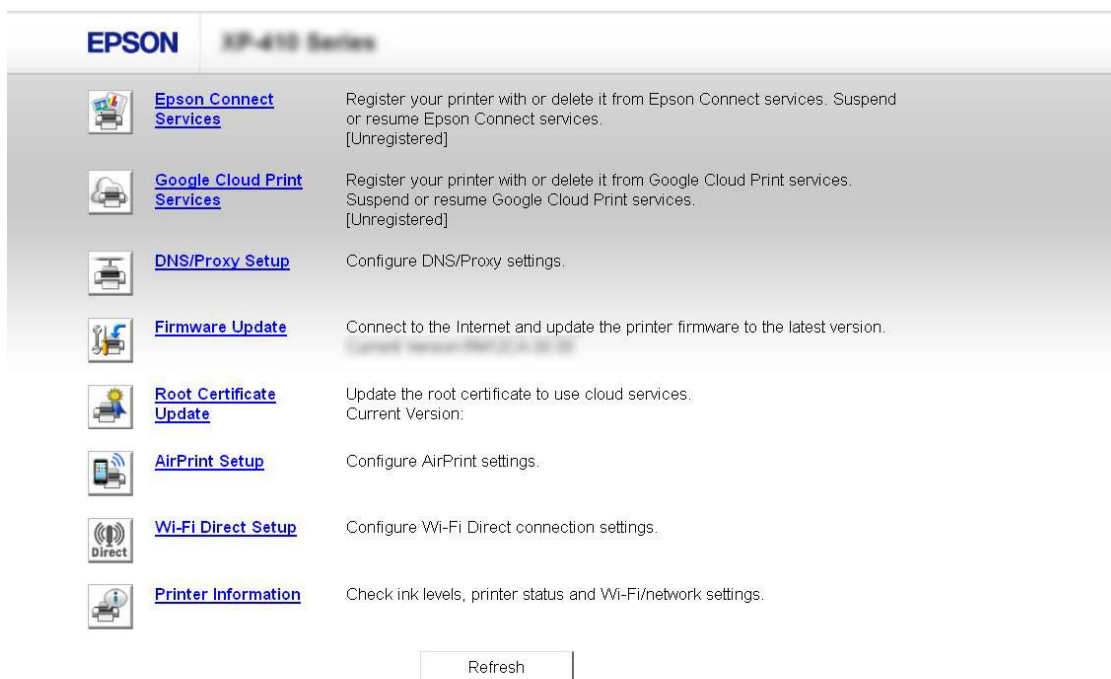

The web page also allows you to check the product's status and update the product's firmware.

Cleaning the Product

Cleaning the exterior of the product

To keep your product operating at its best, clean it thoroughly several times a year by using the following instructions.



Important:

Never use alcohol or thinner to clean the product. These chemicals can damage the product.

Note:

Close the paper support and the output tray when you are not using the product to protect the product from dust.

- Use a soft, dry, clean cloth to clean the LCD screen or touchpad. Do not use liquid or chemical cleaners.
- Use a soft, dry, clean cloth to clean the surface of the scanner glass. If the glass surface is stained with grease or some other hard-to-remove material, use a small amount of glass cleaner and a soft cloth to remove it. Wipe off all remaining liquid.
- Do not press the surface of the scanner glass with any force.

Maintaining Your Product and Software

- ❑ Be careful not to scratch or damage the surface of the scanner glass, and do not use a hard or abrasive brush to clean it. A damaged glass surface can decrease the scan quality.

Cleaning the interior of the product

To keep your print results at their best, clean the roller inside by using the following procedure.

**Caution:**

Be careful not to touch the parts inside the product.

**Important:**

- ❑ *Be careful to keep water away from the electronic components.*
- ❑ *Do not spray the inside of the product with lubricants.*
- ❑ *Unsuitable oils can damage the mechanism. Contact your dealer or a qualified service person if lubrication is needed.*

For product with LCD screen:

- 1 Make sure that no warnings or errors are indicated in the control panel.
- 2 Load several sheets of A4-size plain paper in the sheet feeder.
- 3 Enter **Copy** mode from the **Home** menu.
- 4 Press \diamond to make a copy without placing a document on the scanner glass. Repeat step 4 until the paper is not smeared with ink.

For product without LCD screen:

- 1 Make sure that no warnings or errors are indicated in the control panel.
- 2 Load several sheets of A4-size plain paper in the sheet feeder.
- 3 Press one of the \diamond buttons to make a copy without placing a document on the scanner glass.
- 4 Repeat step 3 until the paper is not smeared with ink.

Transporting the Product

If you need to transport your printer some distance, carefully prepare and repack it as described below. Use the original box and packing materials, or a similar box that holds the printer snugly.

Maintaining Your Product and Software

! **Important:**

- ❑ *When storing or transporting the product, avoid tilting it, placing it vertically, or turning it upside down; otherwise ink may leak.*
- ❑ *Leave the ink cartridges installed. Removing the cartridges can dry out the print head and may prevent the product from printing.*

Note:

The illustrations in this section may vary depending on the product.

- 1** Remove all paper from the sheet feeder and make sure the product is off.
- 2** Open the scanner unit and make sure the print head is in the home position on the right.

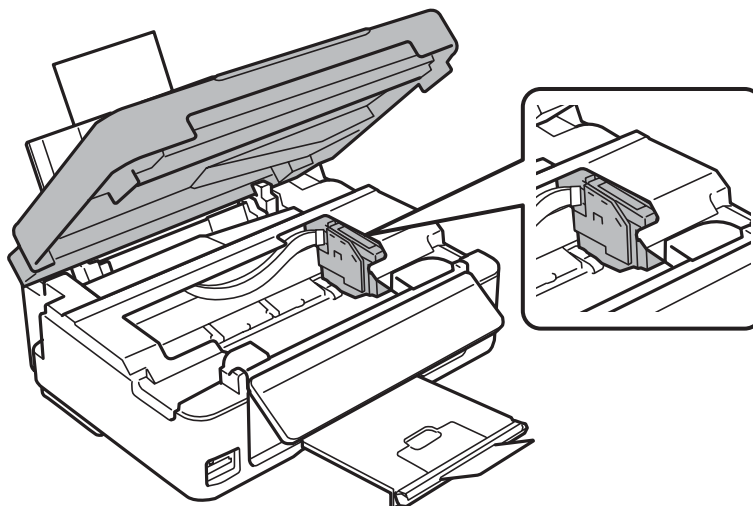

Note:

If the ink cartridge holder is not in the home position on the right, turn on the product and wait until the ink cartridge holder locks in the far right position. Then turn off the product.

Maintaining Your Product and Software

- 3** Secure the ink cartridge holder to the case with tape as shown, then close the scanner unit.

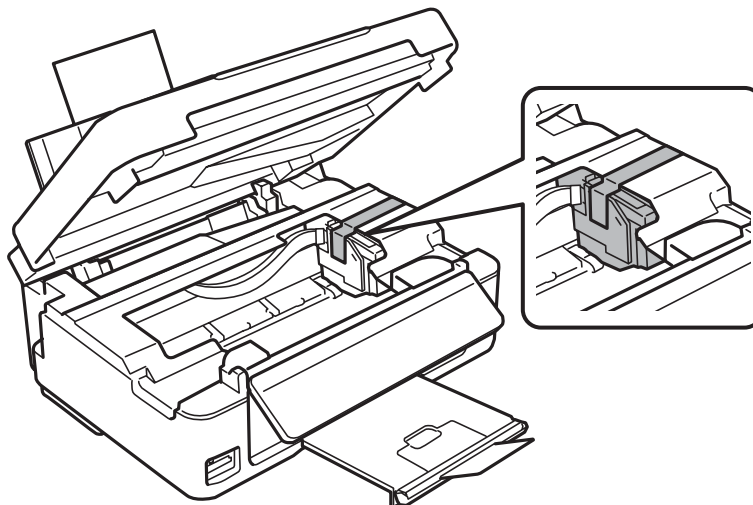

Note:
Do not place tape on the white flat cable inside the product.

- 4** Unplug the power cord from the outlet, then disconnect the USB cable from the product.
- 5** Close the paper support and the output tray.
- 6** If you have raised the control panel, pull the release lever on the rear of the control panel until it clicks, and then lower the control panel to store.

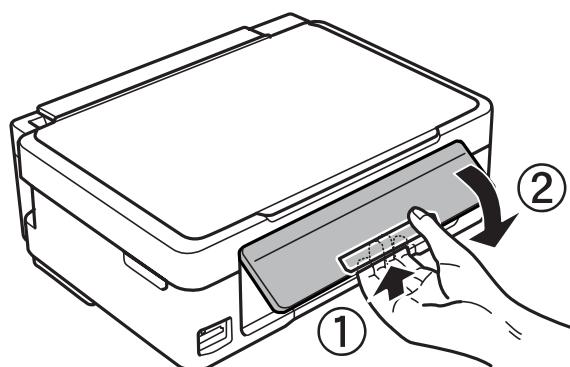

- 7** Repack the product in the box, using the protective materials that came with it.

Note:

- Keep the product level during transport.*
- Be sure to remove the protective materials from the product before using it again.*

Checking and Installing Your Software

Checking the software installed on your computer

To use the functions described in this User's Guide, you need to install the following software.

- Epson Driver and Utilities
- Epson Easy Photo Print
- Epson Event Manager

Follow the steps below to check that the software is installed on your computer.

For Windows

- 1** **Windows 8:** Select **Control Panel** from **Settings**.
Windows 7 and Vista: Click the start button and select **Control Panel**.
Windows XP: Click **Start** and select **Control Panel**.
- 2** **Windows 8, 7 and Vista:** Select **Uninstall a program** from the Programs category.
Windows XP: Double-click the **Add or Remove Programs** icon.
- 3** Check the list of currently installed programs.

For Mac OS X

- 1** Double-click **Macintosh HD**.
- 2** Double-click the **Epson Software** folder in the Applications folder and check the contents.

Note:

- The Applications folder contains software provided by third parties.*
- To check that the printer driver is installed, click **System Preferences** on the Apple menu and then click **Print & Scan** (for Mac OS X 10.8 or 10.7) or **Print & Fax** (for Mac OS X 10.6 or 10.5). Then locate your product in the Printers list box.*

Installing the software

Insert the product software disk that came with your product and select the software you want to install on the Software Select screen.

Maintaining Your Product and Software

If you are using Mac OS X, or if your computer does not have a CD/DVD drive, go to the following Epson website to download and install the software.

<http://support.epson.net/setupnavi/>

Uninstalling Your Software

You may need to uninstall and then reinstall your software to solve certain problems or if you upgrade your operating system.

See the following section for information on determining what applications are installed.

➔ [“Checking the software installed on your computer” on page 109](#)

For Windows

Note:

- For Windows 8, 7 and Vista, you need an administrator account and password if you log on as a standard user.
- For Windows XP, you must log on to a Computer Administrator account.

1 Turn off the product.

2 Disconnect the product's interface cable from your computer.

3 Do one of the following.

Windows 8: Select **Control Panel** from **Settings**.

Windows 7 and Vista: Click the start button and select **Control Panel**.

Windows XP: Click **Start** and select **Control Panel**.

4 Do one of the following.

Windows 8, 7 and Vista: Select **Uninstall a program** from the Programs category.

Windows XP: Double-click the **Add or Remove Programs** icon.

5 Select the software you want to uninstall such as your product's driver and the application from the list displayed.

6 Do one of the following.

Windows 8 and 7: Select **Uninstall/Change** or **Uninstall**.

Windows Vista: Click **Uninstall/Change** or **Uninstall**, and then click **Continue** in the User Account Control window.

Windows XP: Click **Change/Remove** or **Remove**.

Maintaining Your Product and Software

Note:

If you chose to uninstall your product's printer driver in step 5, select the icon for your product and then click **OK**.

7 When the confirmation window appears, click **Yes** or **Next**.

8 Follow the on-screen instructions.

In some cases, a message may appear to prompt you to restart your computer. If so, make sure **I want to restart my computer now** is selected and click **Finish**.

For Mac OS X

Note:

- To uninstall your software you need to download the Uninstaller.
Access the site at:
<http://www.epson.com>
Next, select the support section of your local Epson Web site.
- To uninstall applications, you must log on to a Computer Administrator account.
You cannot uninstall programs if you log on as a limited account user.
- Depending on the application, the Installer may be separated from the Uninstaller.

1 Quit all running applications.

2 Double-click the **Uninstaller** icon in your Mac OS X hard drive.

3 Select the check boxes for the software you want to uninstall, such as the printer driver and the application, from the list displayed.

4 Click **Uninstall**.

5 Follow the on-screen instructions.

If you cannot find the software you want to uninstall in the Uninstaller window, double-click the **Applications** folder in your Mac OS X hard drive, select the application you want to uninstall, and then drag it to the **Trash** icon.

Note:

If you uninstall the printer driver and the name of your product remains in the **Print & Scan** (for Mac OS X 10.8 or 10.7) or **Print & Fax** (for Mac OS X 10.6 or 10.5) window, select the name of your product and click the - **remove** button.

Transferring Data Using an External Storage Device

Note:

The availability of this feature varies by product.

You can use the product's memory card slot to copy files to a computer connected to the product. You can also use it to copy files on your computer to the storage device.

Precautions on Storage Devices

Keep the following in mind when copying files between your storage device and computer:

- Check the documentation that came with your storage device and any adapter you may be using for any handling guidelines.
- Do not copy files to a storage device while you are printing from your storage device.
- The product display does not update information about your storage device after you copy files to it or delete files from it. To update the information displayed, eject and reload the storage device.
- Do not eject your memory card or turn off the product while the memory card light is flashing or you may lose data.

Copying Files Between a Storage Device and Your Computer

Copying files to your computer

1 Make sure the product is turned on and a storage device is connected.

2 **Windows 8:**
Select **All apps** and then select **Computer**.

Windows 7 and Vista:
Click the start button and select **Computer**.

Windows XP:
Click **Start** and select **My Computer**.

Mac OS X:
The removable disk icon () appears on your desktop automatically.

Transferring Data Using an External Storage Device

- 3 Double-click the removable disk icon, then select the folder in which your files are saved.

Note:

If you have set a volume label, it is displayed as the drive name. If you have not set the volume label, "removable disk" is displayed as the drive name on Windows XP.

- 4 Select the files you want to copy and drag them to a folder on your computer's hard drive.



Important:

For Mac OS X users

When you remove the storage device, always drag the removable disk icon on your desktop into the trash before you remove the storage device or you may lose data on the device.

Saving files to a storage device

Note:

If **USB** is selected from the **File Sharing Setup** menu, you cannot write to the memory card from a computer connected through a network. To give write access to the network computer, change the setting to **Wi-Fi**.

➔ ["Setup Mode" on page 78](#)

- 1 Make sure the product is turned on and a storage device is connected.

- 2 **Windows 8:**
Select **All apps** and then select **Computer**.

Windows 7 and Vista:

Click the start button and select **Computer**.

Windows XP:

Click **Start** and select **My Computer**.

Mac OS X:

The removable disk icon () appears on your desktop automatically.

- 3 Double-click the removable disk icon, then select the folder in which you want to save your files.

Note:

If you have set a volume label, it is displayed as the drive name. If you have not set the volume label, "removable disk" is displayed as the drive name on Windows XP.

- 4 Select the folder on your computer's hard drive that contains the files you want to copy. Then select the files and drag them to the folder on your storage device.



Important:

For Mac OS X users

When you remove the storage device, always drag the removable disk icon on your desktop into the trash before you remove the storage device or you may lose data on it.

Error Indicators

Error Messages on the Control Panel (XP-310 Series/ XP-410 Series)

This section describes the meaning of messages displayed on the LCD screen.



XP-410 Series

Error Messages	Solutions
Paper jam.	➔ "Paper Jams" on page 122
Paper out. Load paper.	Load some paper. Otherwise, make sure the number of sheets does not exceed the limit specified for the type of media you are using.
Printer error. Turn power off and on again.	Turn the product off and then back on. Make sure that no paper is still in the product. If the error message still appears, contact Epson support.
Communication error. Connect computer.	Make sure the computer is connected correctly. If the error messages still appears, make sure that scanning software is installed on your computer and that the software settings are correct.
A printer's ink pad is nearing the end of its service life. Please contact Epson Support.	Press  button to resume printing. The message will be displayed until the ink pad is replaced. Contact Epson support to replace ink pads before the end of their service life. When the ink pads are saturated, the product stops and Epson support is required to continue printing.
A printer's ink pad is at the end of its service life. Please contact Epson Support.	Contact Epson support to replace ink pads.
Operation canceled. No memory card recognized.	Make sure the memory card has been inserted correctly. If it is inserted correctly, check to see if there is a problem with the card and try again.
Combination of IP address and subnet mask is invalid. See documentation.	Refer the online Network Guide.
Recovery Mode	The firmware update has failed. You will need to re-attempt the firmware update. Ready a USB cable and visit your local Epson website for further instructions.

XP-310 Series

Code*	Error Messages	Solutions
E-01	Printer error.	Turn the printer off and then back on. Make sure that no paper is still in the printer. If the error still appears, contact Epson support.
E-02	Scanner error.	Turn the printer off and then back on. If the error message still appears, contact Epson support.

Error Indicators









Code*	Error Messages	Solutions
E-10	An ink pad needs service. Contact Epson.	Turn off the printer. Contact Epson support to replace ink pads.
W-02	Paper jam. Remove jammed paper.	Remove the jammed paper, turn off the printer, and then turn it back on. ➔ "Paper Jams" on page 122
W-03	Paper jam. Remove jammed paper.	Open the scanner unit, remove the jammed paper, and then press  . ➔ "Paper Jams" on page 122
W-10	Ink cartridges are installed incorrectly.	The ink cartridge(s) shown on the LCD panel have not been installed. Install them.
W-12	Ink cartridges is not recognized. Please replace cartridges.	Cannot recognize the ink cartridge(s) shown on the LCD panel. Replace the ink cartridge(s). Epson recommends the use of genuine Epson ink cartridges.
W-13	An ink pad is nearing the end of service life.	Press  to resume printing. The message will be displayed until the ink pad is replaced. Contact Epson support to replace ink pads before the end of their service life. When the ink pads are saturated, the printer stops and Epson support is required to continue printing.
I-22	Press the push button of router.	To establish a wireless connection using an access point, press the push button on the access point or click the button on the access point's wireless settings screen displayed on your computer's screen. Refer the online Network Guide.
I-23	Enter PIN to access point.	You need to enter the PIN code displayed on the printer's panel into the access point or computer within two minutes. If no code is entered during the two minutes, a time-out error occurs and a different code is displayed and needs to be entered.
I-31	Install the software on the PC from the CD. Start Wi-Fi setup.	To make wireless connection settings from your computer, you need to insert the CD into the computer and follow the on-screen instructions.
I-60	No computer found.	Your computer may not support WSD (Web Services for Devices). The scan to PC (WSD) function is only available for computers running English versions of Windows 8, 7 or Vista.
-	Recovery Mode	The firmware update has failed. You will need to re-attempt the firmware update. Ready a USB cable and visit your local Epson website for further instructions.

* The code will appear on the top right on the screen.



Error Indications on the Control Panel (XP-210 Series)

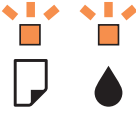

You can identify many common product problems using the lights on your product. If the product stops working and the lights are on or flashing, use the following table to diagnose the problem, then follow the recommended corrective measures.

Error Indicators

Lights	Problem and solution	
	Paper out	
	No paper is loaded.	Load paper into the sheet feeder, and then press one of the start  buttons. The product resumes printing and the light goes out.
	Multiple-paper feed	
More than one sheet has been fed at a time.	Load paper in the sheet feeder correctly and press one of the start  buttons. If the paper remains in the product, see "Paper Jams" on page 122 .	
	Paper jam	
	Paper has jammed in the product.	➔ "Paper Jams" on page 122
	Ink expended	
	An ink cartridge is expended or not installed, or there is insufficient ink in the cartridge to charge the ink.	Replace the ink cartridge for which an error is indicated with a new one. If the light is still on after you have replaced the cartridge, it may not be installed correctly. Reinstall the ink cartridge so that it clicks into place. ➔ "Replacing an Ink Cartridge" on page 89
	Wrong cartridge	
	The currently installed ink cartridge cannot be used with the product. You cannot use the cartridges that came with your product for the replacement.	Replace the incompatible cartridge for which an error is indicated with an appropriate ink cartridge. ➔ "Replacing an Ink Cartridge" on page 89
Incorrectly installed ink cartridge		
An ink cartridge is not installed correctly.	Reinsert the ink cartridge for which an error is indicated. ➔ "An ink error is indicated after you replace the cartridge" on page 133	
	Ink low	
	An ink cartridge is nearly expended.	Obtain a replacement ink cartridge. To determine which cartridge is nearly expended, check the ink cartridge status. ➔ "Checking the Ink Cartridge Status" on page 83
 <p data-bbox="204 1805 308 1863">Flashing alternately</p>	Maintenance	
	The product's ink pads are nearing or at the end of their service life.	Contact Epson support to replace ink pads. If the product's ink pads are nearing the end of their service life, printing can be resumed by pressing one of the start  buttons.

Error Indicators

Lights	Problem and solution	
	<p>Fatal error</p> <p>An unknown product error has occurred.</p> <p>Turn off the product. Then, remove the jammed paper.</p> <p>➔ "Paper Jams" on page 122</p> <p>Then turn the product back on. If the error does not clear, contact your dealer.</p>	
	<p>Wi-Fi network error</p> <p>An error occurred while establishing the Wi-Fi connection.</p> <p>Press the Wi-Fi button to clear the error and try again. For more details, see the online Network Guide.</p>	
	<p>Recovery mode</p> <p>The firmware update has failed, and the product is in recovery mode.</p> <p>You will need to re-attempt the firmware update. Ready a USB cable and visit your local Epson website for further instructions.</p>	

 = on,
  = flashing slowly,
  = flashing fast

Troubleshooting for Printing/Copying

Diagnosing the Problem

Troubleshooting product problems is best handled in two steps: first diagnose the problem, then apply likely solutions until the problem is fixed.

The information that you need to diagnose and solve most common problems is provided by online problem solving, the control panel, or the status monitor. Refer to the appropriate section below.

If you have a specific problem relating to print quality, a printing problem not related to print quality, or a paper feeding problem, or if the product does not print at all, refer to the appropriate section.

To solve a problem, you may need to cancel printing.

➔ [“Canceling Printing” on page 41](#)

Troubleshooting for Printing/Copying

Checking product status

If a problem occurs while printing, an error message will appear in the status monitor window.

If an error message appears indicating the product's ink pads are nearing the end of their service life, contact Epson support to replace them. The message will be displayed at regular intervals until the ink pads are replaced. When the product's ink pads are saturated, the product stops and Epson support is required to continue printing.

For Windows

Note:

The order in which ink cartridges are listed varies depending on the printer.

There are two ways to access EPSON Status Monitor 3:

- Double-click the product shortcut icon on your Windows taskbar. To add a shortcut icon to the taskbar, see the following section:
 - ➔ [“From the shortcut icon on the taskbar” on page 37](#)
- Open the printer driver, click the **Maintenance** tab, then click the **EPSON Status Monitor 3** button.

When you access EPSON Status Monitor 3, the following window appears:

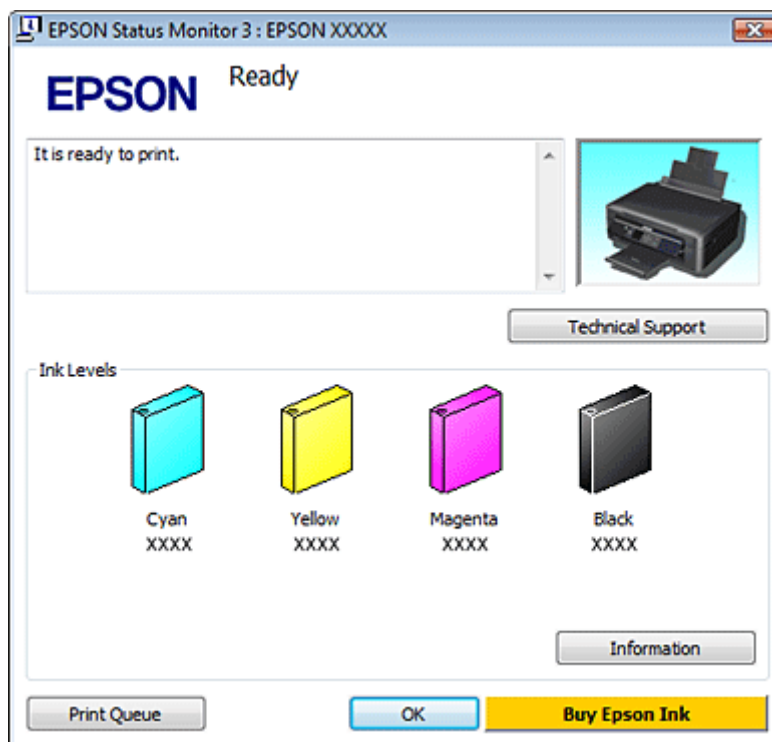

Note:

*If EPSON Status Monitor 3 does not appear, access the printer driver and click the **Maintenance** tab and then the **Extended Settings** button. In the Extended Settings window, check the **Enable EPSON Status Monitor 3** check box.*

EPSON Status Monitor 3 provides the following information:

Troubleshooting for Printing/Copying

- ❑ **Current Status:**
If the ink is low or expended, the **How to** button appears in the EPSON Status Monitor 3 window. Clicking **How to** displays ink cartridge replacement instructions and moves the ink cartridge holder to the ink cartridge replacement position.
- ❑ **Ink Levels:**
EPSON Status Monitor 3 provides a graphic display of the ink cartridge status.
- ❑ **Information:**
You can view information about the installed ink cartridges by clicking **Information**.
- ❑ **Technical Support:**
Click **Technical Support** to access the Epson technical support website.
- ❑ **Print Queue:**
You can view Windows Spooler by clicking **Print Queue**.

For Mac OS X

Note:

The order in which ink cartridges are listed varies depending on the printer.

Follow these steps to access EPSON Status Monitor.

- 1 Access the Epson Printer Utility 4.
➔ [“Accessing the printer driver for Mac OS X” on page 37](#)

Troubleshooting for Printing/Copying

- 2 Click the **EPSON Status Monitor** icon. The EPSON Status Monitor appears.

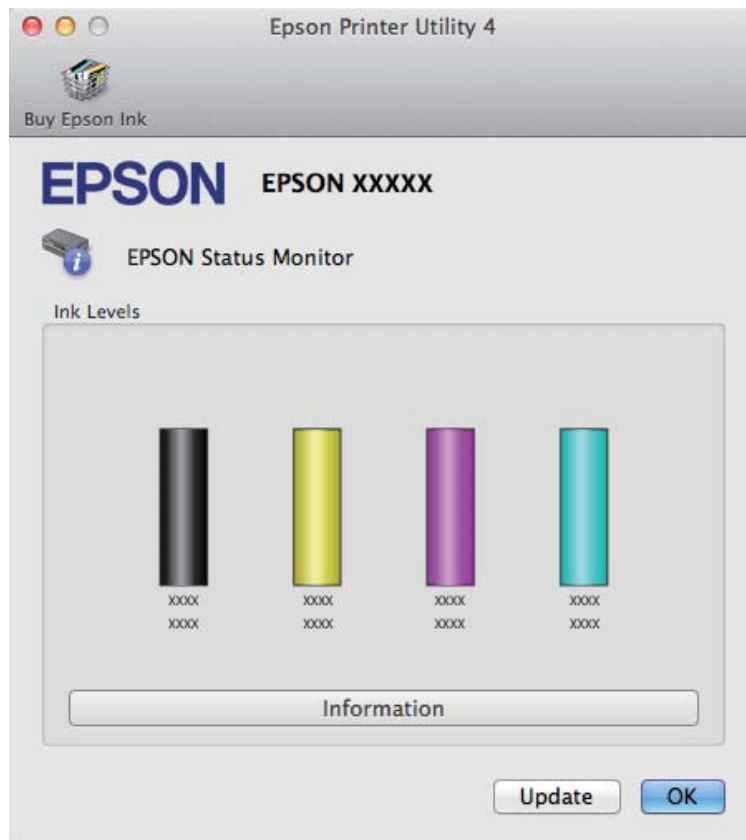

You can also use this utility to check the ink cartridge status before printing. EPSON Status Monitor displays the ink cartridge status at the time it was opened. To update the ink cartridge status, click **Update**.

Troubleshooting for Printing/Copying

When ink is low or expended, a **How to** button appears. Click **How to**, and EPSON Status Monitor will lead you step by step through the ink cartridge replacement procedure.

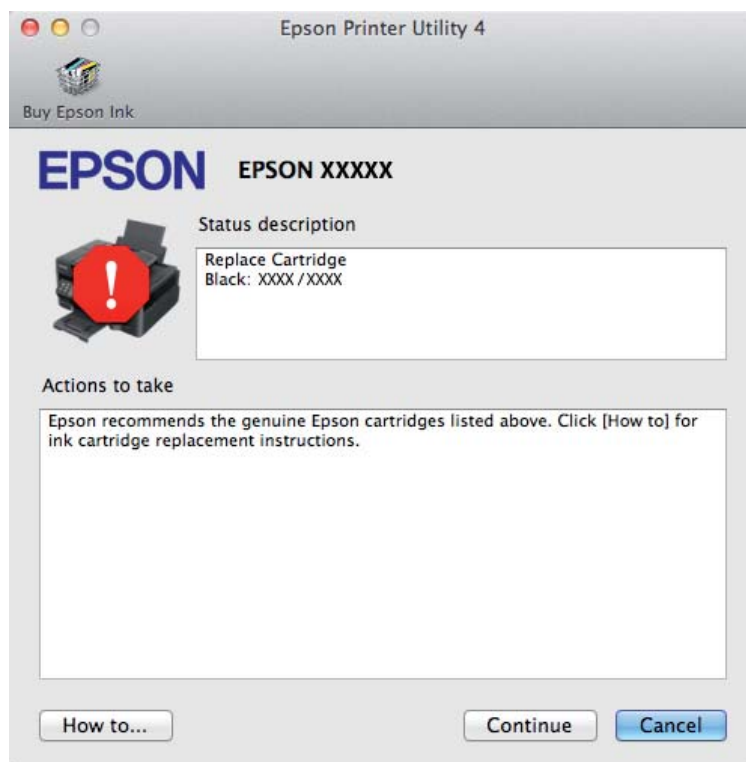

Paper Jams



Caution:

Never touch the buttons on the control panel while your hand is inside the product.

Note:

- The illustrations in this section may vary depending on the product.
- Cancel the print job if prompted by a message from the LCD screen or the printer driver.

Removing jammed paper from inside the product

Note:

The illustrations in this section may vary depending on the product.

1

Cancel the print job if prompted by a message from the printer driver.

➔ [“Canceling Printing” on page 41](#)

Troubleshooting for Printing/Copying

- 2 Open the scanner unit.

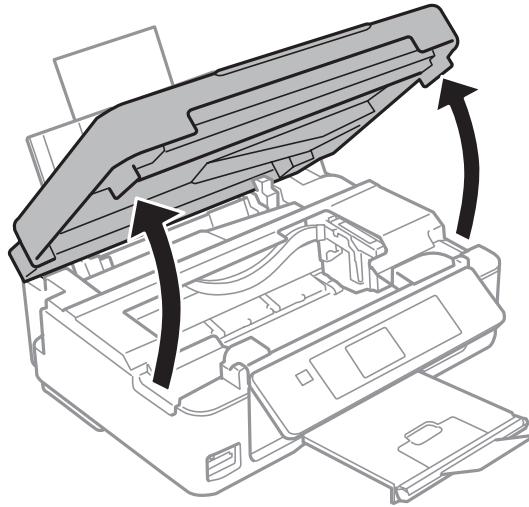

Note:
Some products may come with a scanner unit support.

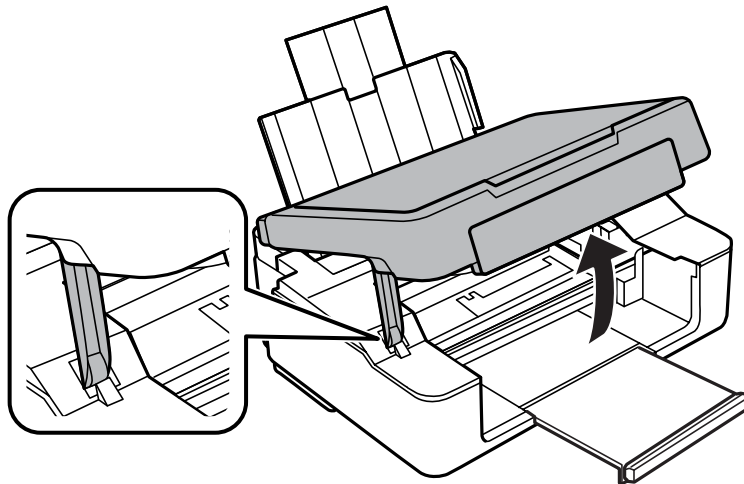

Troubleshooting for Printing/Copying

- 3** Remove all of the paper inside, including any torn pieces.

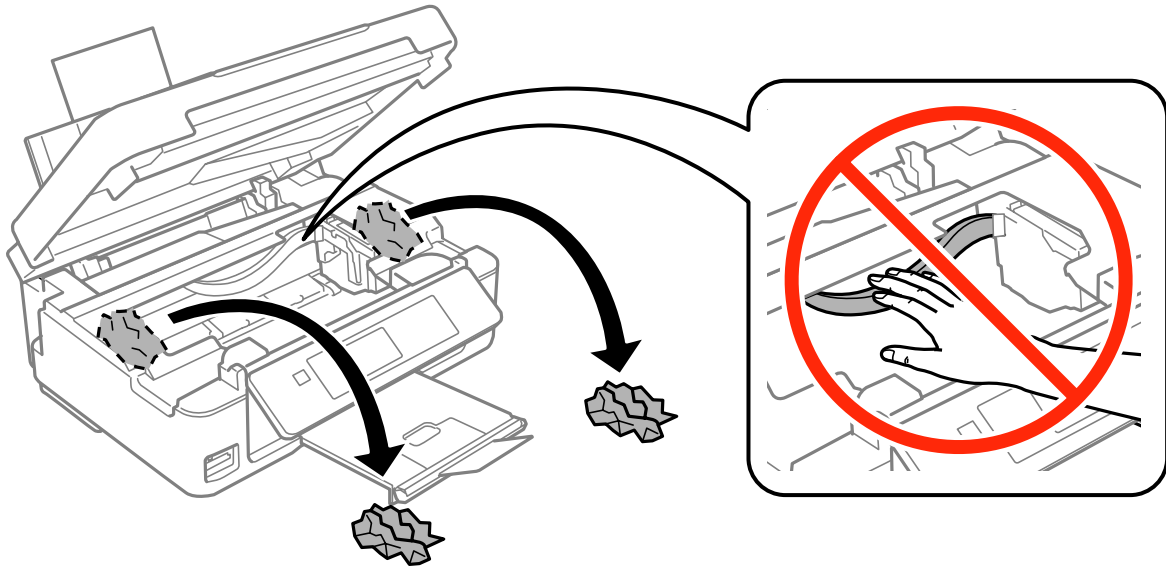

- 4** Close the scanner unit. If the jammed paper remains near the output tray, carefully remove the paper.

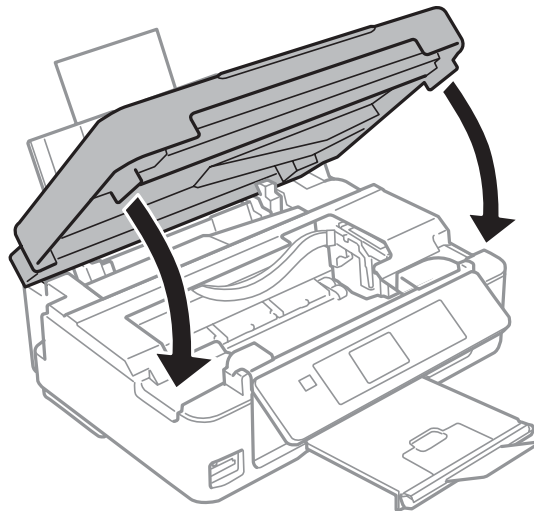

Troubleshooting for Printing/Copying

Note:

If the printer is equipped with a scanner unit support, close the scanner unit as shown below.

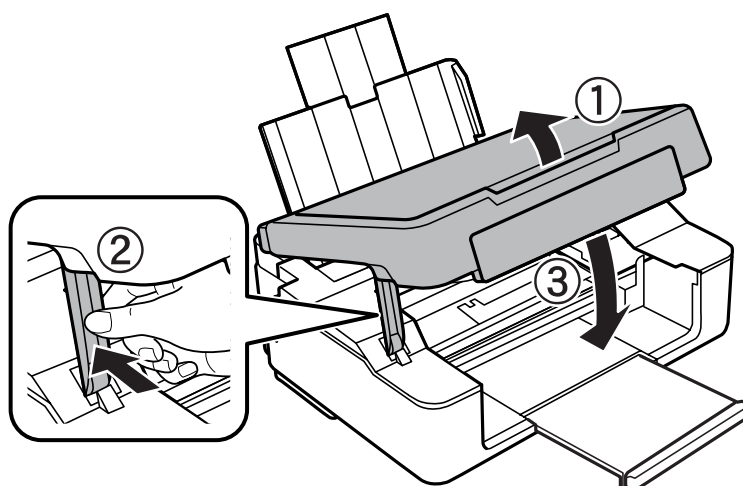

- 5** Press the button indicated in the LCD screen.

For the products without LCD screens: If all the lights on the control panel flash, press the ⏻ button to turn the printer off and then on again. If only the ⏻ and 📄 lights flash, press 🔍 🔍 or 🔍 🔍 button.

Preventing paper jams

If your paper jams frequently, check the following.

- The paper is smooth, not curled or wrinkled.
- You are using high-quality paper.
- The printable side of the paper is face up in the sheet feeder.
- The paper stack was fanned before loading.
- For plain paper, do not load paper above the line just under the ▼ arrow mark inside the edge guide. For Epson special media, make sure the number of sheets is less than the limit specified for the media.
 - ➔ [“Selecting Paper” on page 20](#)
- The edge guides are snug against the edges of the paper.
- The product is on a flat, stable surface that extends beyond the base in all directions. The product will not operate properly if it is tilted.

Reprinting after a paper jam (for Windows only)

After you cancel the print job because of a paper jam, you can reprint it without reprinting pages that have already been printed.



- 1** Solve the paper jam.
 ➔ [“Paper Jams” on page 122](#)

Troubleshooting for Printing/Copying

- 2 Access the printer settings.
 ➔ [“Accessing the printer driver for Windows” on page 36](#)
- 3 Select the **Print Preview** check box in the Main or Advanced window of your printer driver.
- 4 Make the settings that you want to use to print.
- 5 Click **OK** to close the printer settings window, and then print your file. Print Preview window opens.
- 6 Select a page that has already been printed in the page list box on the left side, and then select **Remove Page** from the Print Options menu. Repeat this step for all the pages that have already been printed.
- 7 Click **Print** on the Print Preview window.

Print Quality Help

If you are having print quality problems, then compare it with the illustrations below. Click the caption under the illustration that best resembles your prints.

<p>enthalten alle l Aufdruck. W J 5008 "Regel</p> <p>Good sample</p>	 <p>Good sample</p>
<p>enthalten alle l Aufdruck. W J 5008 "Regel</p> <p>➔ “Horizontal banding” on page 127</p>	<p>enthalten alle l Aufdruck. W J 5008 "Regel</p> <p>➔ “Vertical banding or misalignment” on page 127</p>
 <p>➔ “Horizontal banding” on page 127</p>	 <p>➔ “Vertical banding or misalignment” on page 127</p>

Troubleshooting for Printing/Copying



Horizontal banding

- Make sure the printable side (the whiter or glossier side) of the paper is face up in the sheet feeder.
- Run the Head Cleaning utility to clear any clogged ink nozzles.
 - ➔ "Cleaning the Print Head" on page 99
- For best results, use up ink cartridge within six months of opening the package.
- Try to use genuine Epson ink cartridges.
- Make sure the paper type selected in the LCD menu or printer driver is appropriate for the type of paper loaded in the product.
 - ➔ "Selecting Paper" on page 20
- If banding appears at intervals of 2.5 cm, run the Print Head Alignment utility.
 - ➔ "Aligning the Print Head" on page 101
- If a moire (cross-hatch) pattern appears on your copy, change the **Reduce/Enlarge** setting (XP-410 Series only) in the LCD menu or shift the position of your original.
- If there is problem with copy quality, clean the surface of the scanner glass.
 - ➔ "Cleaning the exterior of the product" on page 105

Vertical banding or misalignment

- Make sure the printable side (the whiter or glossier side) of the paper is face up in the sheet feeder.
- Run the Head Cleaning utility to clear any clogged ink nozzles.
 - ➔ "Cleaning the Print Head" on page 99
- Run the Print Head Alignment utility.
 - ➔ "Aligning the Print Head" on page 101
- For Windows, clear the **High Speed** check box from the Advanced window in your printer driver. See the online help for details.
For Mac OS X, select **Off** from the High Speed Printing. To display the High Speed Printing, click through the following menus: **System Preferences, Print & Scan** (for Mac OS X 10.8 or 10.7) or **Print & Fax** (for Mac OS X 10.6 or 10.5), your product (in the Printers list box), **Options & Supplies**, and then **Driver**.
- Make sure the paper type selected in the LCD menu or printer driver is appropriate for the type of paper loaded in the product.
 - ➔ "Selecting Paper" on page 20

Troubleshooting for Printing/Copying

- ❑ If there is problem with copy quality, clean the surface of the scanner glass.
➔ [“Cleaning the exterior of the product” on page 105](#)

Incorrect or missing colors

- ❑ For Windows, clear the **Grayscale** setting in the Main window in your printer driver.
For Mac OS X, clear the **Grayscale** setting in Print Settings in the Print dialog box in your printer driver.
- ❑ Adjust the color settings in your application or in your printer driver settings.
For Windows, check the Color Management settings in the Advanced window.
For Mac OS X, check the Color Options dialog box from the Print dialog box.
- ❑ Run the Head Cleaning utility to clear any clogged ink nozzles.
➔ [“Cleaning the Print Head” on page 99](#)
- ❑ If you have just replaced an ink cartridge, make sure the date on the box. If you have not used the product for a long time, Epson recommends replacing the ink cartridges.
➔ [“Replacing an Ink Cartridge” on page 89](#)
- ❑ Try to use genuine Epson ink cartridges and paper recommended by Epson.

Blurry or smeared print

- ❑ Try to use genuine Epson ink cartridges and paper recommended by Epson.
- ❑ Make sure the product is on a flat, stable surface that extends beyond the base in all directions. The product will not operate properly if it is tilted.
- ❑ Make sure your paper is not damaged, dirty, or too old.
- ❑ Make sure your paper is dry and the printable side (the whiter or glossier side) is face up in the sheet feeder.
- ❑ If the paper is curled toward the printable side, flatten it or curl it slightly in the opposite direction.
- ❑ Make sure the paper type selected in the LCD menu or printer driver is appropriate for the type of paper loaded in the product.
➔ [“Selecting Paper” on page 20](#)
- ❑ Remove each sheet from the output tray as it is printed.
- ❑ Do not touch or allow anything to come into contact with the printed side of paper with a shiny finish. To handle your prints, follow the instructions of the paper.
- ❑ Run the Head Cleaning utility to clear any clogged ink nozzles.
➔ [“Cleaning the Print Head” on page 99](#)
- ❑ Run the Print Head Alignment utility.
➔ [“Aligning the Print Head” on page 101](#)
- ❑ If the paper is smeared with ink after printing, clean the interior of the product.
➔ [“Cleaning the interior of the product” on page 106](#)

Troubleshooting for Printing/Copying

- ❑ If there is problem with copy quality, clean the surface of the scanner glass.
➔ [“Cleaning the exterior of the product” on page 105](#)

Miscellaneous Printout Problems

Incorrect or garbled characters

- ❑ Clear any stalled print jobs.
➔ [“Canceling Printing” on page 41](#)
- ❑ Turn off the product and computer. Make sure the product's interface cable is securely plugged in.
- ❑ Uninstall the printer driver, then reinstall it.
➔ [“Uninstalling Your Software” on page 110](#)

Incorrect margins

- ❑ Make sure that the paper is loaded into the sheet feeder correctly.
➔ [“Loading Paper and Envelopes” on page 23](#)
- ❑ Check the margin settings in your application. Make sure that the margins are within the printable area of the page.
➔ [“Printable area” on page 144](#)
- ❑ Make sure the printer driver settings are appropriate for the paper size you are using.
For Windows, check the Main window.
For Mac OS X, check the Page Setup dialog box or Print dialog box.
- ❑ Uninstall the printer driver, then reinstall it.
➔ [“Uninstalling Your Software” on page 110](#)

Printout has a slight slant

- ❑ Make sure that the paper is loaded into the sheet feeder correctly.
➔ [“Loading Paper and Envelopes” on page 23](#)
- ❑ If **Fast Economy** is selected in Paper & Quality Options in the Advanced tab in your printer driver (for Windows), or **Fast Economy** is selected in Print Quality in Print Settings (for Mac OS X), select another setting.

Size or position of copied image is incorrect

- ❑ Make sure the paper size, layout, or reduce/enlarge setting (XP-410 Series only) selected in the control panel matches the paper used.
- ❑ If the edges of the copy are cropped off, move the original slightly away from the corner.
- ❑ Clean the scanner glass.
➔ [“Cleaning the exterior of the product” on page 105](#)

Troubleshooting for Printing/Copying

Inverted image

- ❑ For Windows, clear the **Mirror Image** check box from the Page Layout window of your printer driver, or turn off the Mirror Image setting in your application.
For Mac OS X, clear the **Mirror Image** check box in **Print Settings** in the Print dialog box of your printer driver, or turn off the Mirror Image setting in your application.
- ❑ Uninstall the printer driver, then reinstall it.
 - ➔ [“Uninstalling Your Software” on page 110](#)

Blank pages print

- ❑ Make sure the printer driver settings are appropriate for the paper size you are using.
For Windows, check the Main window.
For Mac OS X, check the Page Setup dialog box or Print dialog box.
- ❑ For Windows, check the **Skip Blank Page** setting by clicking the **Extended Settings** button on the Maintenance window of the printer driver.
For Mac OS X, select **On** from the Skip Blank Page. To display the Skip Blank Page, click through the following menus: **System Preferences**, **Print & Scan** (for Mac OS X 10.8 or 10.7) or **Print & Fax** (for Mac OS X 10.6 or 10.5), your product (in the Printers list box), **Options & Supplies**, and then **Driver**.
- ❑ Uninstall the printer driver, then reinstall it.
 - ➔ [“Uninstalling Your Software” on page 110](#)

Printed side is smeared or scuffed

- ❑ If the paper is curled toward the printable side, flatten it or curl it slightly in the opposite direction.
- ❑ Make several copies without placing a document on the scanner glass.
 - ➔ [“Cleaning the interior of the product” on page 106](#)
- ❑ Uninstall the printer driver, then reinstall it.
 - ➔ [“Uninstalling Your Software” on page 110](#)

Printing is too slow

- ❑ Make sure the paper type selected in the LCD menu or printer driver is appropriate for the type of paper loaded in the product.
 - ➔ [“Selecting Paper” on page 20](#)
- ❑ For Windows, choose a lower Paper & Quality Options in the printer driver Advanced tab.
For Mac OS X, choose a lower Print Quality in the Print Settings dialog box from your printer driver's Print dialog box.
 - ➔ [“Accessing the printer driver for Windows” on page 36](#)
 - ➔ [“Accessing the printer driver for Mac OS X” on page 37](#)
- ❑ Close any unnecessary applications.

Troubleshooting for Printing/Copying

- ❑ If you print continuously for an extended period, the printing may be extremely slow. This is to slow down the printing speed and prevent the product mechanism from overheating and being damaged. If this happens, you can continue to print, but we recommend stopping and leaving the product idle for at least 30 minutes with the power on. (The product does not recover with the power off.) After you restart, the product will print at normal speed.
- ❑ Uninstall the printer driver, then reinstall it.
 - ➔ [“Uninstalling Your Software” on page 110](#)

If you try all of the methods above and cannot solve the problem, see the following:

- ➔ [“Increasing the Print Speed \(For Windows Only\)” on page 134](#)

Paper Does Not Feed Correctly

Paper does not feed

Remove the stack of paper and make sure of the following:

- ❑ The paper is not curled or creased.
- ❑ The paper is not too old. See the instructions that came with the paper for more information.
- ❑ For plain paper, do not load paper above the line just under the ▼ arrow mark inside the edge guide. For Epson special media, make sure the number of sheets is less than the limit specified for the media.
 - ➔ [“Selecting Paper” on page 20](#)
- ❑ Paper is not jammed inside the product. If it is, remove the jammed paper.
 - ➔ [“Paper Jams” on page 122](#)
- ❑ The ink cartridges are not expended. If a cartridge is expended, replace it.
 - ➔ [“Replacing an Ink Cartridge” on page 89](#)
- ❑ You have followed any special loading instructions that came with your paper.

Multiple pages feed

- ❑ For plain paper, do not load paper above the line just under the ▼ arrow mark inside the edge guide. For Epson special media, make sure the number of sheets is less than the limit specified for the media.
 - ➔ [“Selecting Paper” on page 20](#)
- ❑ Make sure the edge guides are snug against the edges of the paper.
- ❑ Make sure the paper is not curled or folded. If so, flatten it or curl it slightly toward the opposite side before loading.
- ❑ Remove the stack of paper and make sure that the paper is not too thin.
 - ➔ [“Paper” on page 143](#)
- ❑ Fan the edges of the stack to separate the sheets, then reload the paper.

Troubleshooting for Printing/Copying

- ❑ If too many copies of a file are being printed, check the Copies setting in your printer driver as follows, and also check in your application.
For Windows, check the Copies setting on the Page Layout window.
Mac OS X, check the Copies setting in the Print dialog.

Paper is improperly loaded

If you have loaded the paper too far into the product, the product cannot feed the paper correctly. Turn the product off and gently remove the paper. Then turn the product on and reload the paper correctly.

Paper is not ejected fully or is wrinkled

- ❑ If the paper does not eject fully, press the ⬠ button to eject the paper. For XP-200 Series, press the Ⓞ button to eject the paper. If the paper is jammed inside the product, remove it by referring to the following section.
➔ [“Paper Jams” on page 122](#)
- ❑ If the paper is wrinkled when it comes out, it may be damp or too thin. Load a new stack of paper.

Note:

Store any unused paper in its original packaging in a dry area.

The Product Does Not Print

All lights are off

- ❑ Press the Ⓞ button to make sure the product is on.
- ❑ Make sure that the power cord is securely plugged in.
- ❑ Make sure that your outlet works and is not controlled by a wall switch or timer.

Only the power light is on

- ❑ Turn off the product and computer. Make sure the product's interface cable is securely plugged in.
- ❑ If you are using the USB interface, make sure your cable meets the USB or Hi-Speed USB standards.
- ❑ If you are connecting the product to your computer via a USB hub, connect the product to the first-tier hub from your computer. If the printer driver is still not recognized on your computer, try to directly connect the product to your computer without the USB hub.
- ❑ If you are connecting the product to your computer via a USB hub, make sure the USB hub device is recognized by your computer.
- ❑ If you are trying to print a large image, your computer may not have enough memory. Try reducing the resolution of your image or printing the image at a smaller size. You may need to install more memory in your computer.

Troubleshooting for Printing/Copying



- ❑ Users of Windows can clear any stalled print jobs from the Windows Spooler.
➔ “Canceling Printing” on page 41
- ❑ Uninstall the printer driver, then reinstall it.
➔ “Uninstalling Your Software” on page 110

An ink error is indicated after you replace the cartridge

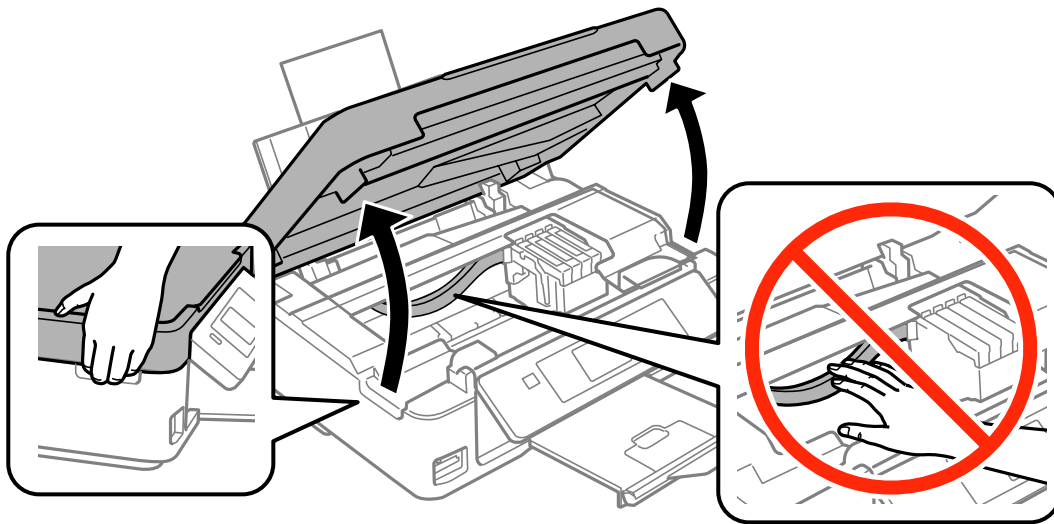
- 1 Open the scanner unit.



- 2 Make sure the ink cartridge holder is at the ink cartridge replacement position.

Note:
For products without LCD screen:
If the ink cartridge holder is at the far right position, press the  button. The ink cartridge holder moves to the ink cartridge check position. The cartridge that is expended or low is indicated by the  mark on this product. Then press the  button again. The ink cartridge holder moves to the ink cartridge replacement position.

- 3 Remove and reinsert the ink cartridge and then continue with the ink cartridge installation. Make sure the top surface of the ink cartridges align.

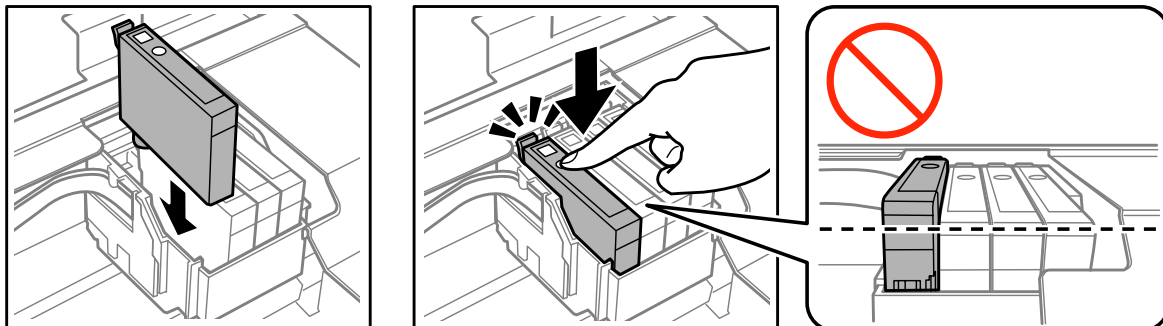

Troubleshooting for Printing/Copying

4 Close the scanner unit slowly and press the button described below.

For products with LCD screen:
Press OK.

For products without LCD screen:
Press .

Increasing the Print Speed (For Windows Only)

Note:

The screen shots in this section may vary depending on the model.

Print speed may be increased by selecting certain settings in the Extended Settings window when the printing speed is slow. Click the **Extended Settings** button on your printer driver's Maintenance window.

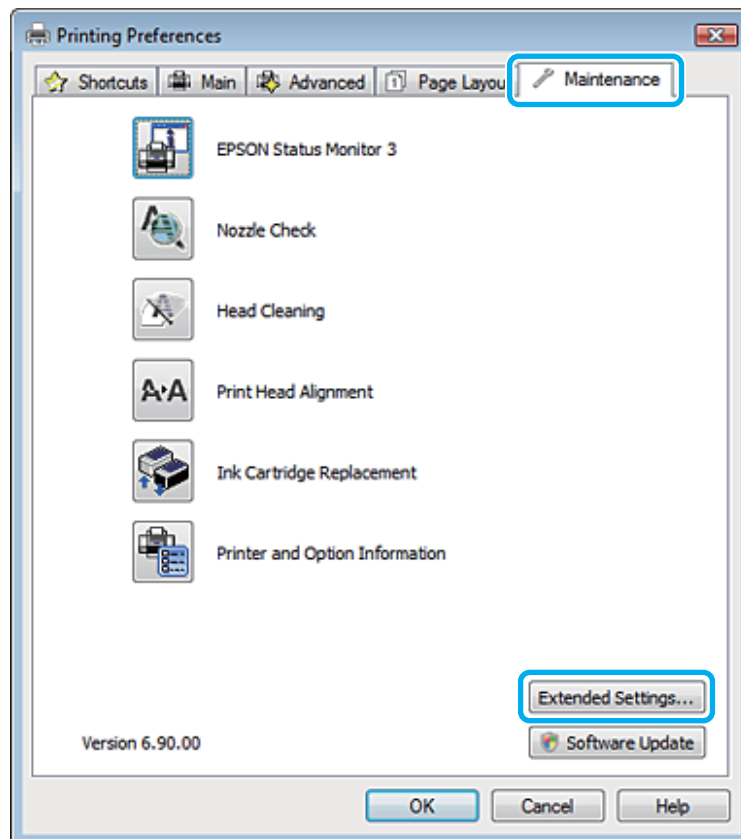

Troubleshooting for Printing/Copying

The following dialog box appears.

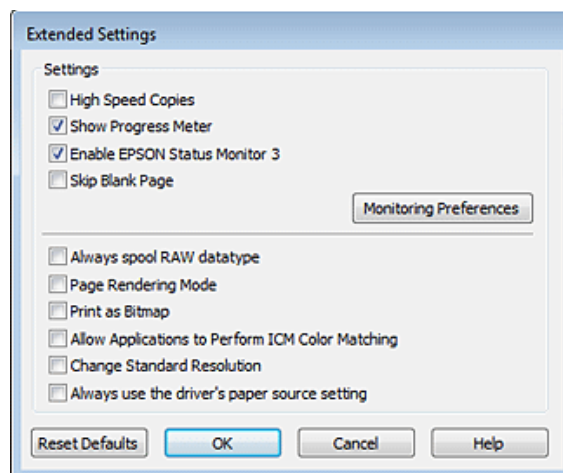

Select the following check boxes and print speed may be increased.

- High Speed Copies
- Always spool RAW datatype
- Page Rendering Mode
- Print as Bitmap

For more details on each item, see the online help.

Other Problem

Printing plain papers quietly

When plain paper is selected for the paper type or Normal is selected as for quality in the printer driver, the product prints at high speed. Try choosing Quiet Mode for quieter operation which will reduce the print speed.

For Windows, select the Quiet Mode check box in the Main window of your printer driver.

For Mac OS X, select **On** from the Quiet Mode. To display the Quiet Mode, click through the following menus: **System Preferences, Print & Scan** (for Mac OS X 10.8 or 10.7) or **Print & Fax** (for Mac OS X 10.6 or 10.5), your product (in the Printers list box), **Options & Supplies**, and then **Driver**.

Troubleshooting for Scanning

Problems Indicated by Messages on the LCD Screen or Status Light

- ❑ Make sure the product is connected to your computer properly.
- ❑ Turn off the product and turn it on again. If the problem is not solved, the product may be malfunctioning, or the light source in the scanner unit may need to be replaced. Contact your dealer.
- ❑ Make sure the scanning software is fully installed.
See the paper manual for instructions on installing the scanning software.

Problems When Starting a Scan

- ❑ Check the status light and make sure the product is ready to scan.
- ❑ Make sure your cables are securely connected to the product and a working electrical outlet.
If necessary, test your product's AC adapter by plugging in another electrical device and turning it on.
- ❑ Turn off the product and computer, and then check the interface cable connection between them to make sure it is secure.
- ❑ Make sure you select the correct product if a scanner list appears when starting to scan.

Windows:

When you start Epson Scan using the EPSON Scan icon, and the Select Scanner list is displayed, make sure you select the model of your product.

Mac OS X:

When you start Epson Scan from the Applications folder and the Select Scanner list is displayed, make sure you select the model of your product.

- ❑ Connect the product directly to the computer's external USB port or through one USB hub only. The product may not work properly when connected to the computer through more than one USB hub. If the problem persists, try connecting the product directly to the computer.
- ❑ If more than one product is connected to your computer, it may not work. Connect only the product you want to use, and then try scanning again.
- ❑ If the scanning software does not work properly, uninstall the software first and then reinstall it as described in the paper manual.
➔ [“Uninstalling Your Software” on page 110](#)

Using the button

Note:

Depending on the product, the scanning function may not be available when using the button.

- Check if you have assigned a program to the button.
 - ➔ [“Epson Event Manager” on page 72](#)
- Make sure Epson Scan and Epson Event Manager are installed correctly.
- If you have clicked the **Keep Blocking** button in the Windows Security Alert window during or after installation of the Epson Software, unblock Epson Event Manager.
 - ➔ [“How to unblock Epson Event Manager” on page 137](#)
- Mac OS X:
Make sure you are logged on as the user who installed the scanning software. Other users must first start Epson Scanner Monitor in the Applications folder and then press a button to scan.

How to unblock Epson Event Manager

1

Click **Start** or the start button, and then point to **Control Panel**.

For Windows 8:

Select **Control Panel** from **Settings**.

2

Do one of the following.

- Windows 8 and 7:
Select **System and Security**.

- Windows Vista:
Select **Security**.

- Windows XP:
Select **Security Center**.

3

Do one of the following.

- Windows 8, 7 and Windows Vista:
Select **Allow a program/an app through Windows Firewall**.

- Windows XP:
Select **Windows Firewall**.

4

Do one of the following.

- Windows 8 and 7:
Confirm that the check box for **EEventManager Application** is selected in the Allowed programs/apps and features list.

Troubleshooting for Scanning

- ❑ Windows Vista:
Click the **Exceptions** tab, and then confirm that the check box for **EEventManager Application** is selected in the Program or port list.
- ❑ Windows XP:
Click the **Exceptions** tab, and then confirm that the check box for **EEventManager Application** is selected in the Programs and Services list.

5

Click OK.

Using scanning software other than Epson Scan driver

- ❑ If you are using any TWAIN-compliant programs, such as Adobe Photoshop Elements, make sure that the correct product is selected as the Scanner or Source setting.
- ❑ If you cannot scan using any TWAIN-compliant scanning programs, such as Adobe Photoshop Elements, uninstall the TWAIN-compliant scanning program and then reinstall it.
➔ [“Uninstalling Your Software” on page 110](#)

Problems When Feeding Paper

The paper gets dirty

You may need to clean the product.

- ➔ [“Cleaning the Product” on page 105](#)

Multiple sheets of paper are fed

- ❑ If you load unsupported paper, the product may feed more than one sheet of paper at a time.
- ❑ You may need to clean the product.
➔ [“Cleaning the Product” on page 105](#)

Problems With Scanning Time

- ❑ Computers with Hi-Speed external USB ports can scan faster than those with external USB ports. If you are using a Hi-Speed external USB port with your product, make sure it meets the system requirements.
➔ [“System Requirements” on page 142](#)
- ❑ Scanning at a high resolution takes a long time.

Problems With Scanned Images

Scan quality is unsatisfactory

Scan quality can be improved by changing the current settings or adjusting the scanned image.

➔ [“Image Adjustment Features” on page 53](#)

An image on the back of your original appears in your scanned image

If your original is printed on thin paper, images on the back may be visible to the product and appear in your scanned image. Try scanning the original with a piece of black paper placed on the back of it. Also make sure the Document Type and Image Type settings are correct for your original.

Characters are distorted or blurred

In Office Mode or Home Mode, select the **Text Enhancement** check box.

Adjust the Threshold setting.

Home Mode:

Select **Black&White** as the Image Type setting, click the **Brightness** button, and then try adjusting the Threshold setting.

Office Mode:

Select **Black&White** as the Image Type setting, and then try adjusting the Threshold setting.

Professional Mode:

Select **Black & White** as the Image Type setting and click the + (Windows) or ► (Mac OS X) button next to **Image Type**. Make the appropriate Image Option setting and then try adjusting the Threshold setting.

Increase the resolution setting.

Characters are not recognized correctly when converted into editable text (OCR)

Place the document so that it is straight on the scanner glass. If the document is skewed, it may not be recognized correctly.

Ripple patterns appear in your scanned image

A ripple or cross-hatch pattern (known as moiré) may appear in a scanned image of a printed document.



Rotate your original document. Rotate the scanned image using the application software after scanning.

Troubleshooting for Scanning

- Select the **Descreening** check box.
- Change a resolution setting and scan again.

Uneven color, smears, dots, or straight lines appear in your image

You may need to clean the interior of the product.

➔ [“Cleaning the Product” on page 105](#)

The scanning area or direction is unsatisfactory

The edges of your original are not scanned

- If you are scanning in Full Auto Mode, or using thumbnail preview in Home Mode or Professional Mode, move the document or photo 6 mm (0.2 inch) away from the horizontal and vertical edges of the scanner glass to avoid cropping.
- If you are scanning using the button or using normal preview in Office Mode, Home Mode, or Professional Mode, move the document or photo about 3 mm (0.12 inch) away from the horizontal and vertical edges of the scanner glass to avoid cropping.

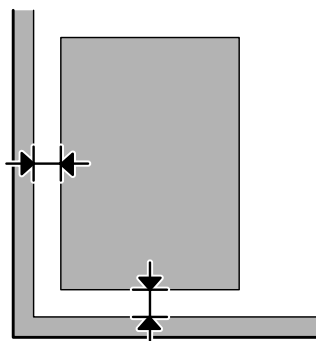

Multiple documents are scanned into a single file

Position documents at least 20 mm (0.8 inch) apart from each other on the scanner glass.

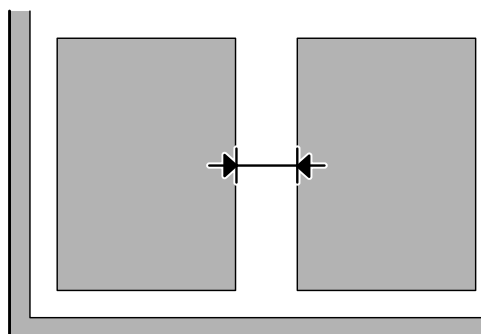

Troubleshooting for Scanning

Cannot scan the area you want

Depending on the documents, you may not be able to scan the area you want. Use normal preview in Office Mode, Home Mode, or Professional Mode and create marquees on the area you want to scan.

Cannot scan in the direction you want

Click **Configuration**, select the **Preview** tab, and then clear the **Auto Photo Orientation** check box. Then, place your documents correctly.

Problems Remain After Trying All Solutions

If you have tried all the solutions and have not solved the problem, initialize the Epson Scan settings.

Click **Configuration**, select the **Other** tab, and then click **Reset All**.

Product Information

Ink Cartridges

You can use the following ink cartridges with this product:

Ink Cartridge	Part numbers			
	XP-212 XP-215 XP-312 XP-315 XP-412 XP-415	XP-213 XP-217 XP-313 XP-413	Singapore, HongKong, Taiwan, Korea XP-312 XP-315 XP-412 XP-415	XP-212
Black	18/18XL	17/17XL	177/178	176/177
Cyan	18/18XL	17/17XL	177	176/177
Magenta	18/18XL	17/17XL	177	176/177
Yellow	18/18XL	17/17XL	177	176/177

Note:

Not all cartridges are available in all regions.

Color	Black, Cyan, Magenta, Yellow
Cartridge life	For best results, use up ink cartridge within six months of opening the package.
Temperature	Storage: -20 to 40 °C (-4 to 104 °F) 1 month at 40 °C (104 °F) Freezing: * -12 °C (10.4 °F)

* Ink thaws and is usable after approximately 3 hours at 25 °C (77 °F).

System Requirements

For Windows

System	PC Interface
Windows 8 (32-bit, 64-bit), Windows 7 (32-bit, 64-bit), Vista (32-bit, 64-bit), XP SP1 or higher(32-bit), or XP Professional x64 Edition	Hi-Speed USB

For Mac OS X

System	PC Interface
Mac OS X 10.5.8, 10.6.x, 10.7.x, 10.8.x	Hi-Speed USB

Note:

The UNIX File System (UFS) for Mac OS X is not supported.

Technical Specifications

Note:

Specifications are subject to change without notice.

Printer specifications

Paper path	Sheet feeder, top entry
Capacity	XP-310 Series/XP-410 Series: 11 mm (0.4in) *1*2 XP-210 Series: 6 mm (0.2in) *1*2

*1 For Legal and User Defined sizes, load one sheet at a time.

*2 Paper with a weight of 64 to 90 g/m²(17 to 24 lb).

Paper

Note:

- Since the quality of any particular brand or type of paper may be changed by the manufacturer at any time, Epson cannot attest to the quality of any non-Epson brand or type of paper. Always test samples of paper stock before purchasing large quantities or printing large jobs.
- Poor quality paper may reduce print quality and cause paper jams or other problems. If you encounter problems, switch to a higher grade of paper.

Single sheets:

Product Information

Size	A4 210 × 297 mm 10 × 15 cm (4 × 6 in.) 13 × 18 cm (5 × 7 in.) A6 105 × 148 mm A5 148 × 210 mm B5 182 × 257 mm 9 × 13 cm (3.5 × 5 in.) 13 × 20 cm (5 × 8 in.) 20 × 25 cm (8 × 10 in.) 16:9 wide size (102 × 181 mm) 100 × 148 mm Letter 8 1/2 × 11 in. Legal 8 1/2 × 14 in.
Paper types	Plain paper or special paper distributed by Epson
Thickness (for plain paper)	0.08 to 0.11 mm (0.003 to 0.004 in.)
Weight (for plain paper)	64 g/m ² (17 lb) to 90 g/m ² (24 lb)

Envelopes:

Size	Envelope #10 4 1/8 × 9 1/2 in. Envelope DL 110 × 220 mm Envelope C6 114 × 162 mm
Paper types	Plain paper
Weight	75 g/m ² (20 lb) to 90 g/m ² (24 lb)

Printable area

Highlighted portions show printable area.

Single sheets:

Normal	Borderless
---------------	-------------------

Product Information

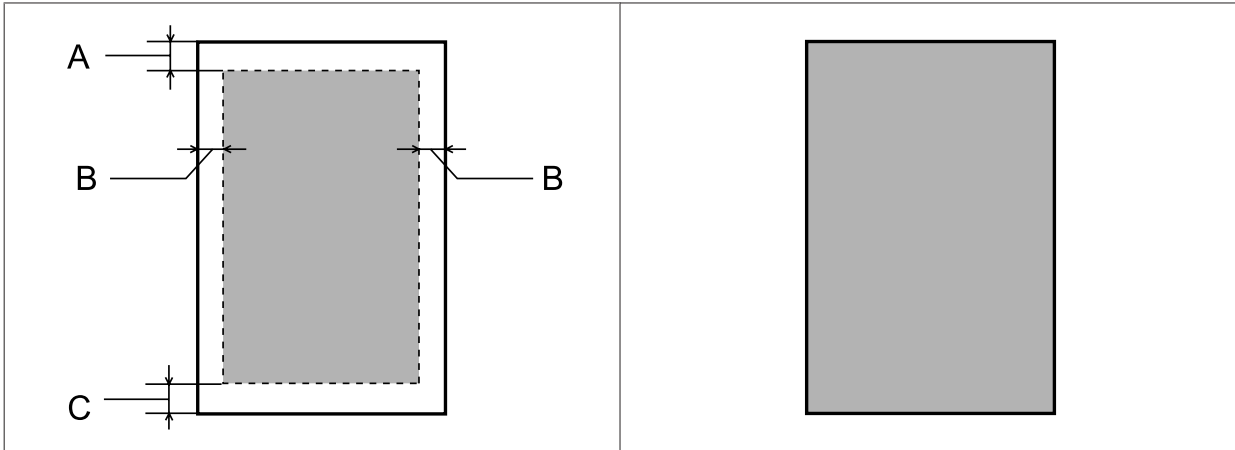

Envelopes:

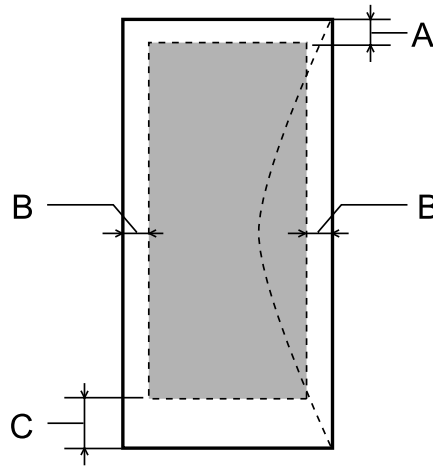

Media type	Minimum margin	
	Single sheets	Envelopes
A	3.0 mm (0.12 in.)	3.0 mm (0.12 in.)
B	3.0 mm (0.12 in.)	5.0 mm (0.20 in.)
C	3.0 mm (0.12 in.)	20.0 mm (0.78 in.)

Note:

Depending on the type of paper, print quality may decline in the top and bottom areas of the print, or the area may be smeared.

Scanner specifications

Scanner type	Flatbed color
Photoelectric device	CIS

Product Information

Effective pixels	10200 × 14040 pixels at 1200 dpi Scanning area may be restricted if resolution setting is large.
Document size	216 × 297 mm (8.5 × 11.7 inches) A4 or US letter size
Scanning resolution	1200 dpi (main scan) 2400 dpi (sub scan)
Output resolution	50 to 4800, 7200, and 9600 dpi (50 to 4800 dpi in 1 dpi increments)
Image data	16 bits per pixel per color internal 8 bits per pixel per color external (maximum)
Light source	LED

Network interface specification

Wi-Fi	Standard:	IEEE 802.11b/g/n ^{*1}
	Security:	WEP (64/128bit) WPA-PSK (TKIP/AES) ^{*2}
	Frequency Band:	2.4 GHz
	Communication Mode:	Infrastructure mode, Ad hoc mode Wi-Fi Direct ^{*3}

*1 Complies with either IEEE 802.11b/g/n or IEEE 802.11b/g depending on location of purchase.

*2 Complies with WPA2 with support for WPA/WPA2 Personal.

*3 XP-210 Series do not support this function.

Memory card

Note:

The availability of this feature varies by product.

Product Information

Compatible memory cards	Memory Stick Duo Memory Stick PRO Duo Memory Stick PRO-HG Duo Memory Stick Micro* MagicGate Memory Stick Duo SDXC SDHC SD miniSDHC* miniSD* microSDXC* microSDHC* microSD*
Media format DCF	DCF (Design rule for Camera File system) version 1.0 or 2.0 compliant. All card types standard version compliant.
Voltage Requirements	3.3 v

* Adapter required.

Photo data specifications

File format	JPEG with the Exif Version 2.3 standard
Image size	80 × 80 pixels to 9200 × 9200 pixels
Number of files	XP-410 Series: up to 9990 XP-310 Series: up to 2000

Mechanical

	XP-210 Series	XP-310 Series	XP-410 Series
Dimensions	Storage Width: 390 mm (15.4 inches) Depth: 300 mm (11.8 inches) Height: 145 mm (5.7 inches)		
	Printing* ¹ Width: 390 mm (15.4 inches) Depth: 504 mm (19.8 inches) Height: 279 mm (11.0 inches)	Printing* ¹ Width: 390 mm (15.4 inches) Depth: 528 mm (20.8 inches) Height: 279 mm (11.0 inches)	
Weight	Approx. 3.9 kg (8.6 lb)* ²	Approx. 4.2 kg (9.3 lb)* ²	Approx. 4.3 kg (9.5 lb)* ²

*¹ With the output tray extension extended.

*² Without the ink cartridges and power cord.

Product Information

Electrical

XP-210 Series

		100-240 V Model
Input voltage range		90 to 264 V
Rated frequency range		50 to 60 Hz
Input frequency range		49.5 to 60.5 Hz
Rated current		0.5 to 0.3 A
Power consumption	Standalone copying	Approx. 12 W (ISO/IEC24712)
	Ready mode	Approx. 5.0 W
	Sleep mode	Approx. 2.7 W
	Power off	Approx. 0.3 W

XP-310 Series

		100-240 V Model
Input voltage range		90 to 264 V
Rated frequency range		50 to 60 Hz
Input frequency range		49.5 to 60.5 Hz
Rated current		0.5 to 0.3 A
Power consumption	Standalone copying	Approx. 13 W (ISO/IEC24712)
	Ready mode	Approx. 6.0 W
	Sleep mode	Approx. 2.7 W
	Power off	Approx. 0.3 W

XP-410 Series

		100-240 V Model
Input voltage range		90 to 264 V
Rated frequency range		50 to 60 Hz
Input frequency range		49.5 to 60.5 Hz
Rated current		0.5 to 0.3 A

Product Information

Power consumption	Standalone copying	Approx. 13 W (ISO/IEC24712)
	Ready mode	Approx. 6.5 W
	Sleep mode	Approx. 2.7 W
	Power off	Approx. 0.3 W

Note:

- Check the label on the back of the product for its voltage.
- For users in Belgium, power consumption when copying may vary. Check <http://www.epson.be> for the latest specifications.

Environmental

Temperature	Operation: 10 to 35 °C (50 to 95 °F) Storage: -20 to 40 °C (-4 to 104 °F) 1 month at 40 °C (104 °F)
Humidity	Operation:* 20 to 80% RH Storage:* 5 to 85% RH

* Without condensation

Standards and approvals

U.S. model:

Safety	UL60950-1 CAN/CSA-C22.2 No.60950-1
EMC	FCC Part 15 Subpart B Class B CAN/CSA-CEI/IEC CISPR 22 Class B

These equipments contains the following wireless module.

Manufacture: Askey Computer Corporation

Type: WLU6117-D69 (RoHS)

This product conforms to Part 15 of the FCC Rules and RSS-210 of the IC Rules. Epson cannot accept responsibility for any failure to satisfy the protection requirements resulting from a non-recommended modification of the product. Operation is subject to the following two conditions: (1) this device may not cause harmful interference, and (2) this device must accept any interference received, including interference that may cause undesired operation of the device.

To prevent radio interference to the licensed service, this device is intended to be operated indoors and away from windows to provide maximum shielding. Equipment (or its transmit antenna) that is installed outdoors is subject to licensing.

Product Information

European model:

Low voltage directive 2006/95/EC	EN60950-1
EMC directive 2004/108/EC	EN55022 Class B EN61000-3-2 EN61000-3-3 EN55024
R&TTE directive 1999/5/EC	EN300 328 EN301 489-1 EN301 489-17 EN60950-1

For European users:

We, Seiko Epson Corporation, hereby declare that the equipment Models, C462K, C462L and C462M are in compliance with the essential requirements and other relevant provisions of Directive 1999/5/EC.

For use only in Ireland, UK, Austria, Germany, Liechtenstein, Switzerland, France, Belgium, Luxembourg, Netherlands, Italy, Portugal, Spain, Denmark, Finland, Norway, Sweden, Iceland, Cyprus, Greece, Slovenia, Malta, Bulgaria, Czech, Estonia, Hungary, Latvia, Lithuania, Poland, Romania, and Slovakia.

Only indoor operation is permitted in France.

If used outside of own premises, general authorization is required in Italy.

Epson can not accept responsibility for any failure to satisfy the protection requirements resulting a non-recommended modification of the products.



Australian model:

EMC	AS/NZS CISPR22 Class B
------------	------------------------

Epson hereby declares that the equipment Models, C462K, C462L and C462M are in compliance with the essential requirements and other relevant provisions of AS/NZS4268. Epson cannot accept responsibility for any failure to satisfy the protection requirements resulting from a non-recommended modification of the product.

Interface

Hi-Speed USB (Device Class for computers)

Where To Get Help

Technical Support Web Site

If you need further help, visit the Epson support website shown below. Select your country or region and go to the support section of your local Epson website. The latest drivers, FAQs, manuals, or other downloadables are also available from the site.

<http://support.epson.net/>

<http://www.epson.eu/Support> (Europe)

If your Epson product is not operating properly and you cannot solve the problem, contact Epson support services for assistance.

Contacting Epson Support

Before Contacting Epson

If your Epson product is not operating properly and you cannot solve the problem using the troubleshooting information in your product documentation, contact Epson support services for assistance. If Epson support for your area is not listed below, contact the dealer where you purchased your product.

Epson support will be able to help you much more quickly if you give them the following information:

- Product serial number
(The serial number label is usually on the back of the product.)
- Product model
- Product software version
(Click **About**, **Version Info**, or similar button in the product software.)
- Brand and model of your computer
- Your computer operating system name and version
- Names and versions of the software applications you normally use with your product

Note:

Depending on the product, the dial list data for fax and/or network settings may be stored in the product's memory. Due to breakdown or repair of a product, data and/or settings may be lost. Epson shall not be responsible for the loss of any data, for backing up or recovering data and/or settings even during a warranty period. We recommend that you make your own backup data or take notes.

Where To Get Help

Help for Users in Europe

Check your **Pan-European Warranty Document** for information on how to contact Epson support.

Help for Users in Taiwan

Contacts for information, support, and services are:

World Wide Web (<http://www.epson.com.tw>)

Information on product specifications, drivers for download, and products enquiry are available.

Epson HelpDesk (Phone: +0280242008)

Our HelpDesk team can help you with the following over the phone:

- Sales enquiries and product information
- Product usage questions or problems
- Enquiries on repair service and warranty

Repair service center:

Telephone number	Fax number	Address
02-23416969	02-23417070	No.20, Beiping E. Rd., Zhongzheng Dist., Taipei City 100, Taiwan
02-27491234	02-27495955	1F., No.16, Sec. 5, Nanjing E. Rd., Songshan Dist., Taipei City 105, Taiwan
02-32340688	02-32345299	No.1, Ln. 359, Sec. 2, Zhongshan Rd., Zhonghe City, Taipei County 235, Taiwan
039-605007	039-600969	No.342-1, Guangrong Rd., Luodong Township, Yilan County 265, Taiwan
038-312966	038-312977	No.87, Guolian 2nd Rd., Hualien City, Hualien County 970, Taiwan
03-2810606	03-2810707	No.413, Huannan Rd., Pingzhen City, Taoyuan County 324, Taiwan
03-5325077	03-5320092	1F., No.9, Ln. 379, Sec. 1, Jingguo Rd., North Dist., Hsinchu City 300, Taiwan
04-23291388	04-23291338	3F., No.510, Yingcai Rd., West Dist., Taichung City 403, Taiwan
04-23805000	04-23806000	No.530, Sec. 4, Henan Rd., Nantun Dist., Taichung City 408, Taiwan
05-2784222	05-2784555	No.463, Zhongxiao Rd., East Dist., Chiayi City 600, Taiwan
06-2221666	06-2112555	No.141, Gongyuan N. Rd., North Dist., Tainan City 704, Taiwan

Where To Get Help

Telephone number	Fax number	Address
07-5520918	07-5540926	1F., No.337, Minghua Rd., Gushan Dist., Kaohsiung City 804, Taiwan
07-3222445	07-3218085	No.51, Shandong St., Sanmin Dist., Kaohsiung City 807, Taiwan
08-7344771	08-7344802	1F., No.113, Shengli Rd., Pingtung City, Pingtung County 900, Taiwan

Help for Users in Australia

Epson Australia wishes to provide you with a high level of customer service. In addition to your product documentation, we provide the following sources for obtaining information:

Your Dealer

Don't forget that your dealer can often help identify and resolve problems. The dealer should always be the first call for advise on problems; they can often solve problems quickly and easily as well as give advise on the next step to take.

Internet URL <http://www.epson.com.au>

Access the Epson Australia World Wide Web pages. Worth taking your modem here for the occasional surf! The site provides a download area for drivers, Epson contact points, new product information and technical support (e-mail).

Epson Helpdesk

Epson Helpdesk is provided as a final backup to make sure our clients have access to advice. Operators on the Helpdesk can aid you in installing, configuring and operating your Epson product. Our Pre-sales Helpdesk staff can provide literature on new Epson products and advise where the nearest dealer or service agent is located. Many types of queries are answered here.

The Helpdesk numbers are:

Phone: 1300 361 054

Fax: (02) 8899 3789

We encourage you to have all the relevant information on hand when you ring. The more information you prepare, the faster we can help solve the problem. This information includes your Epson product documentation, type of computer, operating system, application programs, and any information you feel is required.

Help for Users in Singapore

Sources of information, support, and services available from Epson Singapore are:

World Wide Web (<http://www.epson.com.sg>)

Information on product specifications, drivers for download, Frequently Asked Questions (FAQ), Sales Enquiries, and Technical Support via e-mail are available.

Where To Get Help

Epson HelpDesk (Phone: (65) 6586 3111)

Our HelpDesk team can help you with the following over the phone:

- Sales enquiries and product information
- Product usage questions or problems
- Enquiries on repair service and warranty

Help for Users in Hong Kong

To obtain technical support as well as other after-sales services, users are welcome to contact Epson Hong Kong Limited.

Internet Home Page

Epson Hong Kong has established a local home page in both Chinese and English on the Internet to provide users with the following information:

- Product information
- Answers to Frequently Asked Questions (FAQs)
- Latest versions of Epson product drivers

Users can access our World Wide Web home page at:

<http://www.epson.com.hk>

Technical Support Hotline

You can also contact our technical staff at the following telephone and fax numbers:

Phone: (852) 2827-8911

Fax: (852) 2827-4383

Index**2**

20-up.....	76
2-Sided.....	68
2-sided printing.....	44
2-up.....	76

4

4-up.....	76
-----------	----

8

8-up.....	76
-----------	----

A

Aligning print head.....	101
--------------------------	-----

B

Banding.....	127
Beep.....	79
Blank pages.....	130
Blurry prints.....	128
Borderless print photos.....	74

C

Calendar.....	77
Cancel Photo Selection.....	74
Canceling printing.....	41
Mac OS X.....	42
Windows.....	42
Cleaning print head.....	99
product.....	105
Color problems.....	128
Color Restoration.....	76
Confirm Wi-Fi Settings.....	79
Contacting Epson.....	151
Copy/Restore Photos.....	76
Copying basic.....	29
Copyright.....	2
Crop/Zoom more functions.....	76
print photos.....	74

D

Display Options.....	74, 76
Documents	

printing.....	38
Driver.....	71
accessing for Mac OS X.....	37
accessing for Windows.....	36
uninstalling.....	110

E

Easy Photo Print.....	43
Enlarging pages.....	46
Envelopes loading.....	23
printable area.....	145
Epson Easy Photo Print.....	43
paper.....	20
Epson Connect.....	8, 75
Epson Event Manager.....	72
Error messages.....	114
Errors copy.....	129
print.....	118
scan.....	136

F

File Sharing Setup.....	79
Fit to page printing.....	46
Fix Red-Eye.....	74
Full Auto Mode.....	57

H

Head cleaning control panel.....	100
Mac OS X.....	100
product buttons.....	101
Windows.....	100
Help Epson.....	151
Epson Event Manager.....	72
Epson Scan.....	71
Home Mode.....	58
Horizontal banding.....	127

I

Image Adjustment.....	53
Incorrect characters.....	129
Initialize.....	141
Ink BK printing.....	85
BK printing in Mac.....	87
BK printing in Windows.....	85
checking ink cartridge status in Mac OS X.....	84
checking ink cartridge status in Windows.....	83

Index

- checking ink cartridge status using the control panel.....84
- precaution.....80
- saving black ink in Windows.....88
- temporarily printing with black ink.....85
- Ink cartridges
 - part numbers.....142
 - replacing when expended.....89
- Ink Levels.....78
- Interface cables.....150

- L**
- Layout Method.....76
- Lights
 - flashing.....133
 - status lights.....136
- Lined Papers.....77
- Loading
 - paper.....20, 23
- Lower 1/2.....76

- M**
- Mac OS X
 - accessing printer settings.....37
 - checking product status.....120
- Maintenance.....78
- Managing print jobs
 - Windows.....119
- Manual Wi-Fi/Network Setup.....79
- Margins
 - problems.....129
- Marquee.....65
- Memory card
 - inserting.....26
- Memory cards
 - data specifications.....146
 - supported types.....146
- Message Card.....77
- Mirror image.....130
- Misalignment.....127
- Multiple pages per sheet.....47

- N**
- Nozzle check.....97
 - control panel.....98
 - Mac OS X.....97
 - product buttons.....98
 - Windows.....97

- O**
- Office Mode.....60
- Origami.....77

- P**
- Pages per sheet printing.....47

- Paper
 - Epson special paper.....20
 - feeding problems.....131
 - jams.....122
 - loading.....23
 - loading capacity.....20
 - printable area.....144
 - specifications.....143
 - wrinkling.....132
- Paper jam.....122, 138
- Paper Size
 - more functions.....76
 - print photos.....74
- Paper Type
 - more functions.....76
 - print photos.....74
- PDF.....68
- Personal Stationery.....77
- Photo
 - software.....43
- Photo ID.....76
- Photo Layout Sheet.....76
- Power Off Timer.....79
- Previewing.....64
- Print head
 - aligning.....101
 - checking.....97
 - cleaning.....99
- Print layout.....76
- Print quality
 - improving.....126
- Print Settings.....76
 - more functions.....76
 - print photos.....74
- Print speed
 - increasing.....130, 134
- Printable area specifications.....144
- Printer Setup.....79
- Printing
 - 2-sided.....44
 - borderless.....38
 - canceling.....41
 - document.....38
 - envelope.....38
 - fit to page.....46
 - multiple pages per sheet.....47
 - photo.....38
 - preset.....44
 - shortcut.....44
 - text.....38
- Problems
 - banding.....127
 - blank pages.....130
 - blurry prints.....128
 - contacting Epson.....151
 - diagnosing.....118
 - incorrect characters.....129
 - incorrect colors.....128
 - margins.....129
 - mirror image.....130
 - paper feeding.....131
 - paper jams.....122
 - print.....118

Index

- print speed.....130
- product does not print.....132
- scan.....136
- smear prints.....128, 130
- solving.....151
- Product
- checking status.....119
 - cleaning.....105
 - parts.....14
 - transporting.....106
- Product settings
- accessing for Mac OS X.....37
 - accessing for Windows.....36
 - Power Off Timer.....102
 - Sleep Timer.....102
- Professional Mode.....62
- R**
- Reducing page size.....46
 - Replacing ink cartridges.....89
 - Resizing pages.....46
 - Restore Default Settings.....79
 - Restrictions on copying.....12
- S**
- Safety information.....9
 - Saving energy.....102
 - Scan quality problems.....139
 - Scanner glass.....28
 - Scanning software
 - bundle software.....72
 - Select by Date.....74
 - Select Group.....74
 - Select Photo.....74
 - Select Photos
 - more functions.....76
 - Service.....151
 - Settings.....74
 - Sharing printer
 - Mac OS X.....50
 - Windows.....48
 - Sleep Timer.....79
 - Slide Show.....76
 - Smear prints.....128, 130
 - Software
 - uninstalling.....110
 - Sound.....79
 - Specifications
 - ink cartridges.....142
 - mechanical.....147
 - memory card.....146
 - paper.....143
 - printer.....143
 - scanner.....145
 - standards and approvals.....149
 - Speed
 - increasing.....130, 134
 - Status lights.....136
 - Status Monitor
 - Mac OS X.....120
 - System requirements.....142
- T**
- Technical support.....151
 - Trademarks.....2
 - Transporting product.....106
- U**
- Upper 1/2.....76
 - USB
 - connector.....150
- W**
- Web service.....8, 75, 78
 - Wi-Fi Settings.....79
 - Wi-Fi Setup.....79
 - Wi-Fi/Network Connection Check.....79
 - Wi-Fi/Network Status.....79
 - Windows
 - accessing printer settings.....36
 - checking product status.....119
 - managing print jobs.....119
 - Writing Papers.....77